

MICHIGAN ELECTRIC UTILITY

Generator Interconnection Procedures

Category 2

Projects with

Aggregate Generator Output

***Greater Than 20 kW, but Less Than or Equal to
150 kW¹***

December 2012

¹ Additionally, Non-Certified, Non-Compliant IEEE 1547 et seq inverter, synchronous or induction projects with an Aggregate Generator Output of 20kW or Less.

Introduction

Category 2 – Greater than 20kW but less than or equal to 150kW¹

This Generator Interconnection Procedure document outlines the process & requirements used to install or modify generation projects with aggregate generator output capacity ratings greater than 20kW but less than or equal to 150kW¹ and designed to operate in parallel with the Utility electric system. Technical requirements are defined according to type of generation, location of the interconnection, and mode of operation (Flow-back or Non-Flow-back). The process is designed to allow for a reasonably expeditious interconnection to the Utility electric system that is both safe and reliable.

This document has been filed with the Michigan Public Service Commission (MPSC) and complies with rules established for the interconnection of parallel generation to the Utility electric system in the MPSC Order in Case No. U-15787.

The term “Project” will be used throughout this document to refer to electric generating equipment and associated facilities that are not owned or operated by an Electric Utility. The term “Project Developer” means a person that owns, operates, or proposes to construct, own, or operate, a Project.

This document does not address other Project concerns such as environmental permitting, local ordinances, or fuel supply. Nor does it address agreements that may be required with the Utility, an Alternate Electric Supplier, and/or the transmission provider, or state or federal licensing, to market the Project’s energy. An interconnection request does not constitute a request for transmission or establishment / modification of existing electrical lines or electric service.

When requested by the Project Developer, it may be possible for the Utility to adjust requirements stated herein on a case-by-case basis. The review necessary to support such adjustments, however, may be extensive and may exceed the ordinary costs and timeframes addressed in these requirements. Therefore, if requested by the Project Developer, adjustments to these requirements will only be considered if the Project Developer agrees in advance to compensate the Utility for the actual and reasonably and prudently incurred added costs that are not otherwise recovered, if any, of the additional reviews, and to also allow the utility a reasonable amount of additional time for the additional reviews.

The Utility may apply for a technical waiver from one or more provisions of these rules and the MPSC may grant a waiver.

Non Certified Inverter based generation projects, synchronous and induction projects less than or equal to 20kW are defined as Category 2 projects and are implemented under the Category 2 procedures and applications.

Table of Contents

INTERCONNECTION PROCESS	5
<i>Customer Project Planning Phase</i>	5
<i>Application</i>	5
<i>Application Review</i>	5
<i>Engineering Review</i>	6
<i>Distribution Study</i>	6
<i>Distribution Upgrades & Construction Agreement</i>	6
<i>Project Developer Install & Parallel Operating Agreement (POA)</i>	7
<i>Meter Install, Testing, & Inspection</i>	7
<i>Operation in Parallel</i>	7
OPERATIONAL PROVISIONS	8
<i>Disconnection</i>	8
<i>Maintenance and Testing</i>	8
<i>Operating in Parallel</i>	9
<i>Momentary Paralleling</i>	10
TECHNICAL REQUIREMENTS.....	11
MAJOR COMPONENT DESIGN REQUIREMENTS.....	11
<i>Data</i>	11
<i>Isolating Transformer(s)</i>	11
<i>Isolation Device</i>	12
<i>Interconnection Lines</i>	12
<i>Relaying Design Requirements</i>	13
<i>Automatic Reclosing</i>	13
<i>Single-Phase Sectionalizing</i>	14
<i>Synchronous Projects</i>	14
<i>Induction Projects</i>	14
<i>Inverter Projects</i>	14
<i>Dynamometer Projects</i>	15
<i>Relay Setting Criteria</i>	15
<i>Maintenance and Testing</i>	15
<i>Installation Approval</i>	15
MISCELLANEOUS OPERATIONAL REQUIREMENTS	16
<i>Reactive Power Control</i>	16
<i>Site Limitations</i>	16
<i>Revenue Metering Requirements</i>	17
<i>Non Flow-back Projects</i>	17
<i>Flow-back Projects</i>	17
COMMUNICATION CIRCUITS	18
APPENDIX A-INTERCONNECTION PROCESS FLOW DIAGRAM	19
APPENDIX B-INTERCONNECTION & NET METERING COSTS AND TIMELINES	23
APPENDIX C- DEFINITIONS.....	24
APPENDIX D-SAMPLE SITE PLAN.....	28

APPENDIX E-SAMPLE ONE-LINE SYNCHRONOUS PROJECTS 29
APPENDIX F-SAMPLE ONE-LINE INDUCTION PROJECTS 31
APPENDIX G-SAMPLE ONE-LINE INVERTER PROJECTS..... 33
APPENDIX H-SAMPLE ONE-LINE DIAGRAM FOR NON-FLOW BACK PROJECTS 35
APPENDIX I-SAMPLE ONE-LINE DIAGRAM FOR FLOW-BACK PROJECTS 36

Interconnection Procedures

Interconnection Process

Customer Project Planning Phase

An applicant may contact the Utility before or during the application process regarding the project. The Utility can be reached by phone, e-mail, or by the external website to access information, forms, rates, and agreements. A Utility will provide up to 2 hours of technical consultation at no additional cost to the applicant. Consultation may be limited to providing information concerning the Utility system operating characteristics and location of system components.

Application

The Project Developer must first submit an Interconnection application or a Combined Interconnection and Net Metering application to the Utility. A separate application is required for each Project or Project site. The blank Interconnection Application or Combined Interconnection and Net Metering application can be found on the Electric Utility's website (insert link).

An applicant shall complete a submittal of required interconnection application and Interconnection filing fee per the table in Appendix B. The Utility will notify the Project Developer within 10 business days of receipt of an Interconnection Application. If any portion of the Interconnection Application, data submittal (a site plan and the one-line diagrams), or filing fee is incomplete and/or missing, the Utility will return the application, data, and filing fee to the Project developer with explanations. Project Developer will need to resubmit the application with all the missing items.

Once the Utility has accepted the combined Interconnection and Net Metering Application, an identifying number will be assigned to the Project. The Utility will then advise the applicant that the application is complete and provide the customer with the identifying number.

Application Review

The Utility will review the complete application for interconnection to determine if additional Study(ies)² are required. The Utility will notify the Project Developer within 10 business days of receipt of a complete application and if additional study(ies) are required. The applicant shall provide any changes or updates to the application before additional Study(ies) begin. The Utility may request additional data be submitted as necessary during the review phase to clarify the operation of the Project. If the additional study(ies) are not required and the interconnection is

² Affected System Studies, Engineering Review, and/or Distribution Studies.

approved, the project will advance to the Customer Install, & POA phase of the process. If the interconnection is disapproved, the utility shall notify the applicant of the necessary corrective actions required for approval. The applicant, after taking corrective action, may request the electric utility to reconsider the interconnection request.

Engineering Review

Upon receipt of the executed Engineering Review Agreement, the Utility will study the project to determine the suitability of the interconnection equipment including safety and reliability complications arising from equipment saturation, multiple technologies, and proximity to synchronous motor loads. The electric utility shall provide in writing the results of the engineering study within the time indicated per table Appendix B. If the engineering review indicates that a Distribution Study is necessary, the Electric Utility shall notify the applicant of the requirements for the Distribution Study. If an Engineering Review determines that a Distribution Study is not required, the project will advance to the **Project Developer Install & POA phase**.

Distribution Study

Upon receipt of the executed Distribution Study Agreement and submission of the Distribution Study Fee (per table Appendix B), the Utility shall study the project to determine if a Distribution System upgrade is needed to accommodate the proposed project and determine the cost of the upgrade as required. The Project Developer is responsible for the actual cost for the Distribution Study & Distribution Upgrades as required. The electric utility shall provide in writing the results of the Distribution Study including estimated completion timeframe for the upgrades, if required, to the applicant, within the timeframe per table Appendix B. Additionally the Utility will provide a letter outlining the actual cost to perform the Distribution Study and require a cost true up with the applicant. If a Distribution Study determines that distribution upgrades are not required, the project will advance to the **Project Developer Install & POA**.

Distribution Upgrades & Construction Agreement

Upon the applicants acceptance of the Distribution Study results, and if Distribution System upgrades are required, the Electric Utility will provide the applicant a Distribution System Construction Agreement³. The applicant shall submit an executed Distribution System Construction Agreement and full Payment for the estimated construction cost with 10% contingency fee. The Distribution System construction agreement will include a construction completion time estimate within a mutually agreed upon construction schedule. Design and Build of the Distribution System Upgrades will commence with a fully executed Distribution System Construction Agreement and full payment.

³ Additional agreements may be required to address Affected System issues associated with the project.

Project Developer Install & Parallel Operating Agreement (POA)

The applicant shall notify the Electric Utility when the Project Developer installation and any required local code inspection and approval is complete. The Parallel Operating Agreement will cover matters customarily addressed in such agreements in accordance with Good Utility Practice, including, without limitation, system operation, interconnection rate, defaults and remedies, and liability. The applicant shall complete, sign and return the POA to the Utility. Any delay in the applicant's execution of the Interconnection and Operating Agreement will not toll the interconnection deadlines. The applicant's project will advance to the Meter Install, Testing, & Inspection phase upon the completion of the Distribution System Upgrades.

Meter Install, Testing, & Inspection

Upon receipt of the local code inspection approval and POA executed by the applicant, the Utility will schedule the meter install, testing, and inspection. The Utility shall have an opportunity to schedule a visit to witness and perform commissioning tests required by IEEE 1547 et seq., and inspect the project. The Electric Utility may provide a waiver of its right to visit the site to inspect the project and witness or perform the commissioning tests. The Utility shall notify the applicant of its intent to visit the site, inspect the project, witness or perform the commissioning tests, or of its intent to waive inspection within 10 working days after notification that the installation and local code inspections have passed. Within 5 working days from receipt of the completed commissioning test report (if applicable), the Utility will notify the applicant of its final approval or disapproval of the interconnection. The utility's review is limited to determining whether the project was constructed consistent with the previously approved application and satisfactory completion of the commissioning tests (as applicable). If the project was constructed consistent with the application and passes the commissioning test, then the project shall be awarded final approval for parallel operation and the Utility will execute the POA or otherwise approve operation. If the project was not constructed consistent with the application or does not pass the commissioning test, the utility may deny final approval for parallel operation. If the electric utility does not award final approval for the interconnection, the utility shall notify the applicant of the necessary corrective actions required for approval. The applicant, after taking corrective action, may request the electric utility to reconsider the interconnection request.

Operation in Parallel

Upon Utility approval of the interconnection, the Electric Utility shall install required metering, provide to the applicant a written statement of final approval, and letter identifying the actual cost of the Distribution System upgrades. Upon completion of the cost true up of the actual cost for the Distribution System upgrades the Utility will provide a fully executed POA authorizing parallel operation.

Operational Provisions

Disconnection

An Electric Utility may refuse to connect or may disconnect a project from its distribution system if any of the following conditions apply:

- a. Applicant has not complied with any one of the technical requirements contained in the applicable Interconnection Procedures,
- b. The electrical characteristics of the Applicant Facility are not compatible with the electrical characteristics of Utility's distribution system,
- c. An emergency condition exists on Utility's distribution system,
- d. Applicant's protective relay equipment fails,
- e. Utility determines that the Applicant Facility is disrupting service to any Utility Customer,
- f. Disconnection is required to allow for construction, installation, maintenance, repair, replacement, removal, investigation, inspection or testing of any part of Utility's facilities,
- g. If a required installation fails or becomes incapacitated and is not repaired in a timely manner, as determined by Utility
- h. Applicant commits a material breach of the POA or otherwise fails to make payment for services rendered by Utility or violates Utility's tariff(s)

Maintenance and Testing

The Utility reserves the right to test the relaying and control equipment that involves protection of the Utility's electric system, at its sole expense, whenever the Utility determines a need for such testing exists.

The applicant is solely responsible for conducting and documenting proper periodic maintenance on the generating equipment and its associated control, protective equipment, interrupting devices, and main Isolation Device⁴, per manufacturer recommendations.

Routine and maintenance checks of the relaying and control equipment must be conducted in accordance with provided written test procedures which are required by IEEE Std. 1547, and test reports of such testing shall be maintained by the applicant and made available for Utility inspection upon request. [NOTE – IEEE 1547 requires that testing be conducted in accordance with written test procedures, and the nationally recognized testing laboratory providing certification will require that such test procedures be available before certification of the equipment.]

⁴ Main Isolation Device - When required by the Electric Utility operating practices, a readily accessible, lockable, visible-break isolation device located between the Electric Utility and the Project

Operating in Parallel

The Project Developer will be solely responsible for the required synchronizing equipment and for properly synchronizing the Project with the Utility's electric system.

Voltage fluctuation at the Point of Common Coupling (PCC) during synchronization is limited per IEEE Std. 1547 et seq.

These requirements are directly concerned with the actual operation of the Project with the Utility:

- The Project may not commence parallel operation until approval has been given by the Utility. The completed installation is subject to inspection by the Utility prior to approval. Preceding this inspection, all contractual agreements must be executed by the Project Developer.
- The Project must be designed to prevent the Project from energizing into a de-energized Utility line. The Project's circuit breaker or contactor must be blocked from closing in on a de-energized Electric Utility's distribution system.
- The Project shall discontinue parallel operation with a particular service and perform necessary switching when requested by the Utility for any of the following reasons:
 1. When public safety is being jeopardized.
 2. During voltage or loading problems, system emergencies, or when abnormal sectionalizing or circuit configuration occurs on the Utility system.
 3. During scheduled shutdowns of Utility equipment that are necessary to facilitate maintenance or repairs.
 4. In the event there is demonstrated electrical interference (i.e. Voltage Flicker, Harmonic Distortion, etc.) to the Utility's customers, suspected to be caused by the Project, and such interference exceeds then current system standards, the Utility reserves the right, to install special test equipment as may be required to perform a disturbance analysis and monitor the operation and control of the Project to evaluate the quality of power produced by the Project. In the event that no standards exist, then the applicable tariffs and rules governing electric service shall apply. If the Project is the source of the interference, and that interference exceeds the Utility's standards or generally accepted industry standards, then it shall be the responsibility of the Project Developer to eliminate the interference problem.
 5. When either the Project or its associated synchronizing and protective equipment is demonstrated by the Utility to be improperly maintained, so as to present a hazard to the Utility system or its customers.

6. Whenever the Project is operating isolated with other Utility customers, for whatever reason.
7. Whenever the Utility notifies the Project Developer in writing of a non-safety related violation of the Interconnection Agreement and the Project Developer fails to remedy the violation within ten working days of notification.

If the Project has shown an unsatisfactory response to requests to separate the generation from the Utility system, the Utility reserves the right to disconnect the Project from parallel operation with the Utility electric system until all operational issues are satisfactorily resolved.

Momentary Paralleling

For situations where the Project will only be operated in parallel with the Utility's electric system for a short duration (100 milliseconds or less), as in a make-before-break automatic transfer scheme, no additional relaying is required. Such momentary paralleling requires a modern integrated Automatic Transfer Switch (ATS) system, which is incapable of paralleling the Project with the Utility's electric system. The ATS must be tested, verified, and documented by the Project Developer for proper operation at least every 2 years. The Utility may be present during this testing.

Technical Requirements

The following discussion details the technical requirements for interconnection of Category 2 Projects. For Projects within this capacity rating range, the Utility has made a significant effort to simplify the technical requirements. This effort has resulted in adoption of IEEE Standard 1547, Standard for Interconnecting Distributed Resources with Electric Power Systems, being incorporated herein by reference. All protective functions are compliant with IEEE Standard 1547 et seq.

Certain requirements, as specified by this document, must be met to provide compatibility between the Project and the Utility's electric system, and to assure that the safety and reliability of the electric system is not degraded by the interconnection. The Utility reserves the right to evaluate and apply newly developed protection and/or operation schemes at its discretion. In addition, the Utility reserves the right to evaluate Projects on an ongoing basis as system conditions change, such as circuit loading, additional generation placed online, etc. Upgraded revenue metering may be required for the Project.

Major Component Design Requirements

The data requested in Appendix E, F, or G for all major equipment and relaying proposed by the Project Developer, must be submitted as part of the initial application for review and approval by the Utility. The Utility may request additional data be submitted as necessary during the Engineering Review and/or Distribution Study phase to clarify the operation of the Project.

Once installed, the interconnection equipment must be reviewed and approved by the Utility prior to being connected to the Utility's electric system and before Parallel Operation is allowed.

Data

The data that the Utility requires to evaluate the proposed interconnection is documented on a one-line diagram and "fill in the blank" table by generator type in Appendices E, F, or G. A site plan, one-line diagrams, and interconnection protection system details of the Project are required as part of the application data. The generator manufacturer supplied data package should also be supplied.

Isolating Transformer(s)

If a Project Developer installs an isolating transformer, the transformer must comply with the ANSI Standard C57.12 – 1999, unless a more recent standard is agreed to by the Project Developer and the Utility.

The transformer should have high and/or low voltage windings sufficient to assure satisfactory generator operation over the range of voltage variation expected on the Utility electric system. The type of generation and electrical location of the interconnection will determine the isolating transformer connections. Allowable connections are detailed in the “Specific Requirements by Generator Type” section. Note: Some Utilities do not allow an isolation transformer to be connected to a grounded Utility system with an ungrounded secondary (Utility side) winding configuration, regardless of the Project type. Therefore, the Project Developer is encouraged to consult with the Utility prior to submitting an application.

Isolation Device

When required by the Electric Utility operating practices, a readily accessible, lockable, visible-break isolation device will be located between the Electric Utility and the Project. It can be a rackable circuit breaker, circuit switcher, pole top switch, load-break disconnect, etc., depending on the electrical system configuration. The following are required of the isolation device:

- Must be approved for use on the Utility system.
- Must comply with relevant ANSI and/or IEEE Standards.
- Must have load break capability, unless used in series with a three-phase interrupting device.
- Must be rated for the application.
- If used as part of a protective relaying scheme, it must have adequate interrupting capability. The Utility will provide maximum short circuit currents and X/R ratios available at the PCC, upon request.
- Must be operable and accessible by the Utility at all times (24 hours a day, 7 days a week).
- The Utility will determine if the isolation device will be used as a protective tagging point. If the determination is so made, the device must have a visible open break provisions for padlocking in the open position and it must be gang operated. If the device has automatic operation, the controls must be located remote from the device.

Interconnection Lines

Any new line construction to connect the Project to the Utility’s electric system will be undertaken by the Utility at the Project Developer's expense. The new line(s) will terminate on a utility approved structure provided by and paid for by the Project Developer.

The physically closest available system voltage, as well as equipment and operational constraints influence the chosen point of interconnection. The Utility has the ultimate authority to determine the acceptability of a particular PCC.

Relaying Design Requirements

Regardless of the technology of the interconnection, for simplicity for all projects in this capacity rating range, the interconnection relaying system must be certified by a nationally recognized testing laboratory to meet IEEE Std. 1547. The data submitted for review must include information from the manufacturer indicating such certification, and the manufacturer must placard the equipment such that a field inspection can verify the certification. A copy of this standard may be obtained (for a fee) from the Institute of Electrical and Electronics Engineers (www.ieee.org).

If the protective system uses AC power as the control voltage, it must be designed to disconnect the generation from the Utility electric system if the AC control power is lost. Utility will work with Project Developer for system design for this requirement.

Automatic Reclosing

The Utility employs automatic multiple-shot reclosing on most of the Utility's circuit breakers and circuit reclosers to increase the reliability of service to its customers. Automatic single-phase overhead reclosers are regularly installed on distribution circuits to isolate faulted segments of these circuits.

The Project Developer is advised to consider the effects of Automatic Reclosing (both single-phase and three-phase) to assure that the Project's internal equipment will not be damaged. In addition to the risk of damage to the Project, an out-of-phase reclosing operation may also present a hazard to Utility equipment since this equipment may not be rated or built to withstand this type of reclosing. The Utility will determine relaying and control equipment that needs to be installed to protect its own equipment from out-of-phase reclosing. Installation of this protection will be undertaken by the Utility at the Project Developer's expense.

In some cases, recloser settings can be modified to prevent out-of-phase reclosing. This could delay reclosing until the parallel generation is separated and the line is "de-energized". Hydraulic single-phase overhead recloser settings cannot be modified; therefore, these devices will have to be either replaced with three-phase overhead reclosers whose settings can be changed, or relocated beyond the Project location - depending upon the sectionalizing and protection requirements of the distribution circuit. If the Project can be connected to more than one circuit, these revisions may be required on the alternate circuit(s) as well. The Utility shall not be liable to the customer with respect to damage(s) to the Project arising as a result of Automatic Reclosing.

Single-Phase Sectionalizing

The Utility also installs single-phase fuses and/or reclosers on its distribution circuits to increase the reliability of service to its customers. Three-phase generator installations may require replacement of fuses and/or single-phase reclosers with three-phase circuit breakers or circuit reclosers at the Project Developer's expense.

Synchronous Projects

An isolation transformer will be required for three-phase Synchronous Projects. Except as noted below, the isolation transformer must be incapable of producing ground fault current to the Utility system; any connection except delta primary (Project side), grounded-wye secondary (Utility side) is acceptable. A grounded-wye - grounded-wye transformer connection is acceptable only if the Project's single line-to-ground fault current contribution is less than the Project's three-phase fault current contribution at the PCC. Protection must be provided for internal faults in the isolating transformer; fuses are acceptable.

For a sample One-Line Diagram of this type of facility, see Appendix E.

Induction Projects

For three-phase installations, any isolation transformer connection is acceptable except grounded-wye (Utility side), delta (Project side). Protection must be provided for internal faults in the isolating transformer; fuses are acceptable. In cases where it can be shown that self excitation of the induction generator cannot occur when isolated from the Utility, the Utility may waive the requirement that the generator provide protection for Utility system ground faults. For a sample One-Line Diagram of this type of facility, see Appendix F.

Inverter Projects

No isolation transformer is required between the generator and the secondary distribution connection. If an isolation transformer is used for three-phase installations, any isolation transformer connection is acceptable except grounded-wye (Utility side), delta (Project side). Protection must be provided for internal faults in the isolating transformer; fuses are acceptable. Utility may waive the requirement that the Project Developer provide protection for the Utility system ground faults.

For a sample One-Line Diagram of this type of facility, see Appendix G.

Dynamometer Projects

No isolation transformer is required between the generator and the secondary distribution connection. If an isolation transformer is used for three-phase installations, any isolation transformer connection is acceptable except grounded-wye (Utility side), delta (Project side). Protection must be provided for internal faults in the isolating transformer; fuses are acceptable.

If an inverter is used and has passed a certified anti-island test, the Utility may waive the requirement that the Project Developer provide protection for the Utility system ground faults.

Relay Setting Criteria

The relay settings for Projects greater than 20 kW but less than or equal to 150 kW must conform to the values specified in IEEE Std. 1547.

Maintenance and Testing

The Utility reserves the right to test the relaying and control equipment that involves protection of the Utility electric system whenever the Utility determines a reasonable need for such testing exists.

The Project Developer is solely responsible for conducting proper periodic maintenance on the generating equipment and its associated control, protective equipment, interrupting devices, and main Isolation Device, per manufacturer recommendations.

Routine Maintenance checks of the relaying and control equipment must be conducted in accordance with provided written test procedures which are required by IEEE Std. 1547, and test reports of such testing shall be maintained by the Project Developer and made available for Utility inspection upon request. [NOTE – IEEE 1547 requires that testing be conducted in accordance with written test procedures, and the nationally recognized testing laboratory providing certification will require that such test procedures be available before certification of the equipment.]

Installation Approval

The Project Developer must provide the Utility with 5 business days advance written notice of when the Project will be ready for inspection, testing, and approval.

Prior to final approval for Parallel Operation, the Utility reserves the right to inspect the Project and receive action to assure conformance to the requirements stated herein.

Miscellaneous Operational Requirements

Miscellaneous requirements include synchronizing equipment for Parallel Operation, reactive requirements, and system stability limitations.

Reactive Power Control

Synchronous generators that will operate in the Flow-back Mode must be dynamically capable of providing 0.90 power factor lagging (delivering reactive power to the Utility) and 0.95 power factor leading (absorbing reactive power from the Utility) at the Point of Receipt. The Point of Receipt is the location where the Utility accepts delivery of the output of the Project. The Point of Receipt can be the physical location of the billing meters or a location where the billing meters are not located, but adjusted for line and transformation losses.

Induction and Inverter Projects that will operate in the Flow-back Mode must provide for their own reactive needs (steady state unity power factor at the Point of Receipt). To obtain unity power factor, the Induction or Inverter Project can:

1. Install a switchable Volt-Ampere reactive VAR supply source to maintain unity power factor at the Point of Receipt; or
2. Provide the Utility with funds to install a VAR supply source equivalent to that required for the Project to attain unity power factor at the Point of Receipt at full output.

There are no interconnection reactive power capability requirements for Synchronous, Induction, and Inverter Projects that will operate in the Non-Flow-back Mode. The Utility's existing rate schedules, incorporated herein by reference, contain power factor adjustments based on the power factor of the metered load at these facilities.

Site Limitations

The Project Developer is responsible for evaluating the consequences of unstable generator operation or voltage transients on the Project equipment, and determining, designing, and applying any relaying which may be necessary to protect that equipment. This type of protection is typically applied on individual generators to protect the generator facilities

The Utility will determine if operation of the Project will create objectionable voltage flicker and/or disturbances to other Utility customers and develop any required mitigation measures at the Project Developer's expense.

Revenue Metering Requirements

The Utility will own, operate, and maintain all required billing metering equipment . An electric provider serving over 1,000,000 customers shall provide a meter or meters capable of measuring the flow of energy in both directions at the Electric Utility's cost. An electric provider serving less than 1,000,000 customers shall provide a meter or meters capable of measuring the flow of energy in both directions at the Project Developer's expense.

Non Flow-back Projects

A Utility meter will be installed that only records energy deliveries to the Project.

Flow-back Projects

Special billing metering will be required. The Project Developer may be required to provide, at no cost to the Utility, a dedicated dial-up voice-grade circuit (POTS line) to allow remote access to the billing meter by the Utility. This circuit shall be terminated within ten feet of the meter involved.

The Project Developer shall provide the Utility access to the premises reasonable times to install, turn on, disconnect, inspect, test, read, repair, or remove the metering equipment. The Project Developer may, at its option, have a representative witness this work.

The metering installations shall be constructed in accordance with the practices, which normally apply to the construction of metering installations for residential, commercial, or industrial customers. For Projects with multiple generators, metering of each generator may be required. When practical, multiple generators may be metered at a common point provided the metered quantity represents only the gross generator output.

The Utility shall supply to the Project Developer all required metering equipment and the standard detailed specifications and requirements relating to the location, construction, and access of the metering installation and will provide consultation pertaining to the meter installation as required. The Utility will endeavor to coordinate the delivery of these materials with the Project Developer's installation schedule during normal scheduled business hours.

The Project Developer may be required to provide a mounting surface for the metering equipment. The mounting surface and location must meet the Utility's specifications and requirements.

The responsibility for installation of the equipment is shared between the Utility and the Project Developer. The Project Developer may be required to install some of the metering equipment on

its side of the PCC, including instrument transformers, cabinets, conduits, and mounting surfaces. The Utility shall install the meters and appropriate communication links. The Utility will endeavor to coordinate the installation of these items with the Project Developer's schedule during normal scheduled business hours.

Communication Circuits

The Project Developer is responsible for ordering and acquiring the telephone circuit required for the Project Interconnection. The Project Developer will assume all installation, operating, and maintenance costs associated with the telephone circuits, including the monthly charges for the telephone lines and any rental equipment required by the local telephone provider. However, at the Utility's discretion, the Utility may select an alternative communication method, such as wireless communications. The Utility will reasonably consider wireless communication or other communication methods if they are less costly than traditional telephone circuits. Regardless of the method, the Project Developer will be responsible for all costs associated with the material, installation and maintenance, whereas the Utility will be responsible to define the specific communication requirements.

The Utility will cooperate and provide Utility information necessary for proper installation of the telephone (or alternate) circuits upon written request.

Appendix A-Interconnection Process Flow Diagram

Category 2 Projects – Non Affected System
 (Interconnection projects greater than 20 kW but less than or equal to 150 kW and non-inverter based 20 kW and less that do not impact another electric utility system.)
 Interconnection Process Flow Diagram

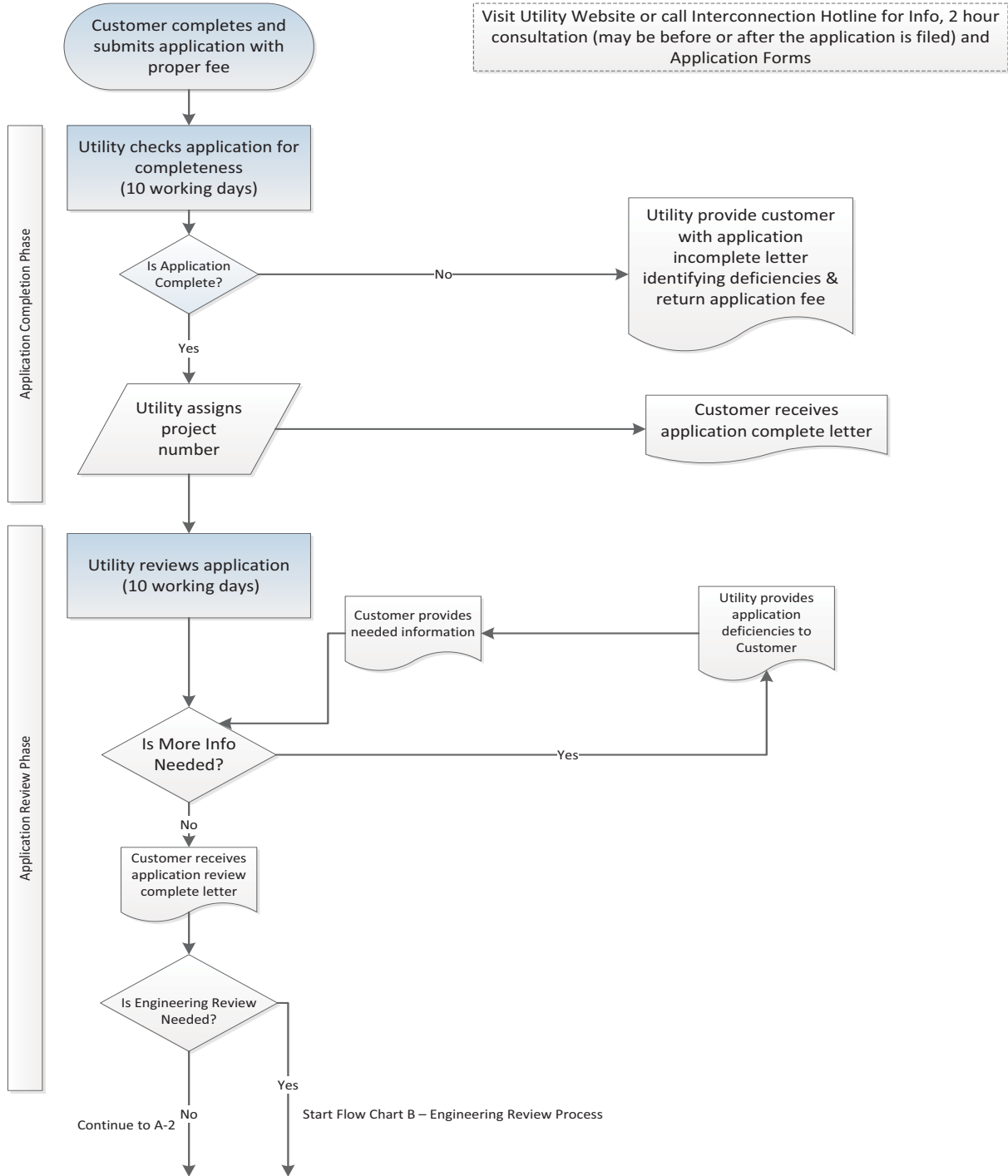

FLOW CHART A-2
Category 2 Projects – Non Affected System

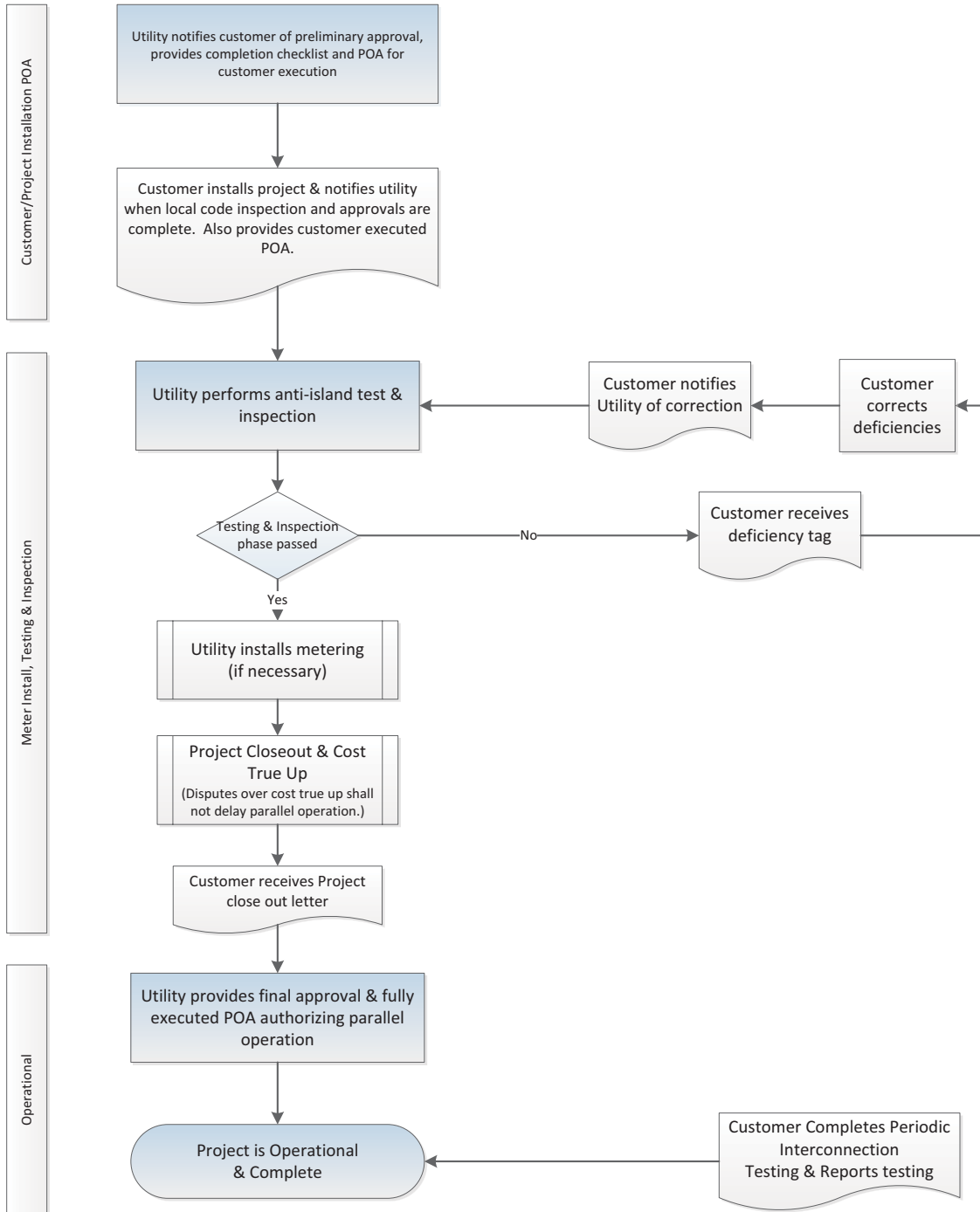

**FLOW CHART B (Engineering Review Process)
Category 2 Projects – Non Affected System**

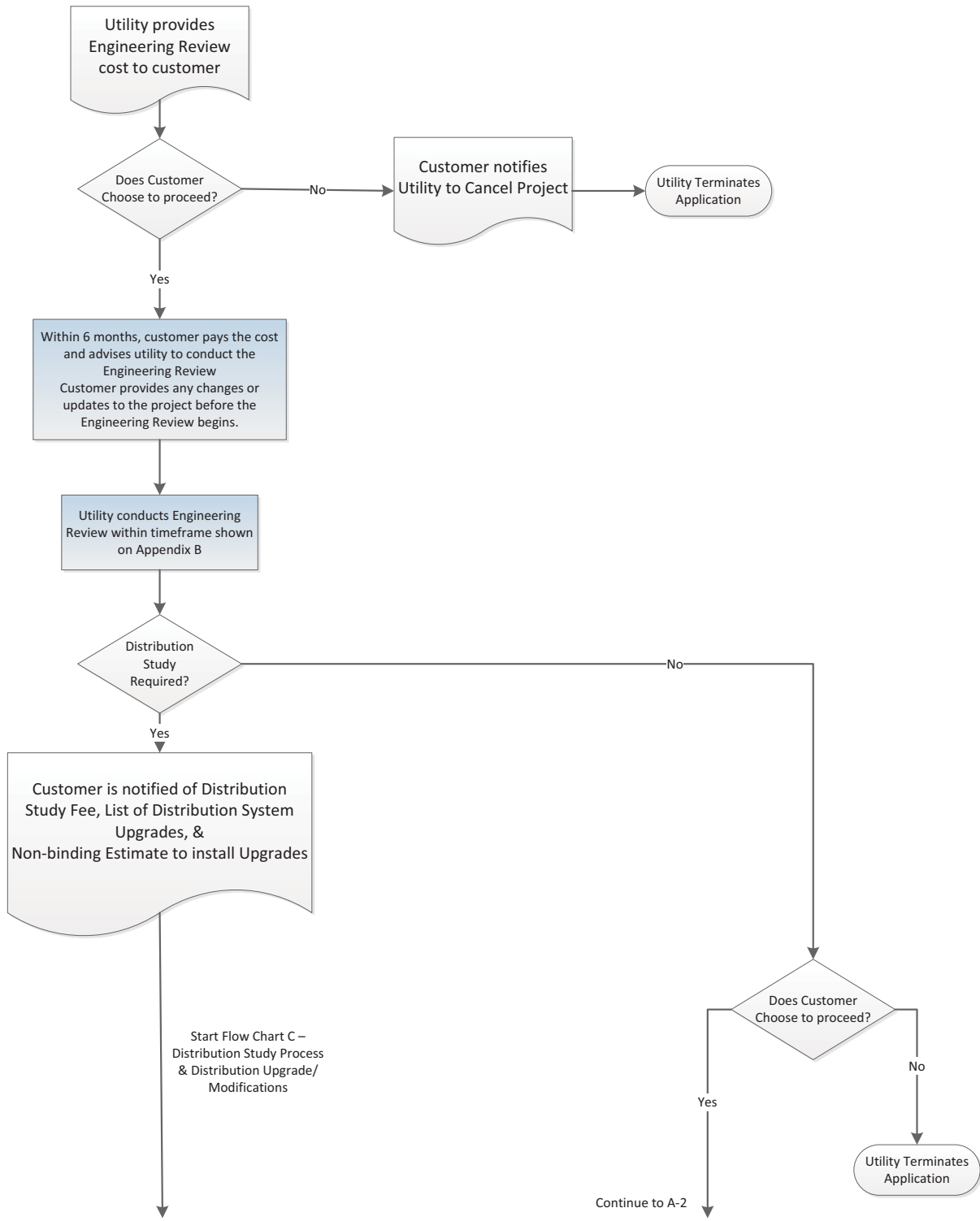

**FLOW CHART C (Distribution Study Process & Distribution Upgrade/Modifications)
Category 2 Projects – Non Affected System**

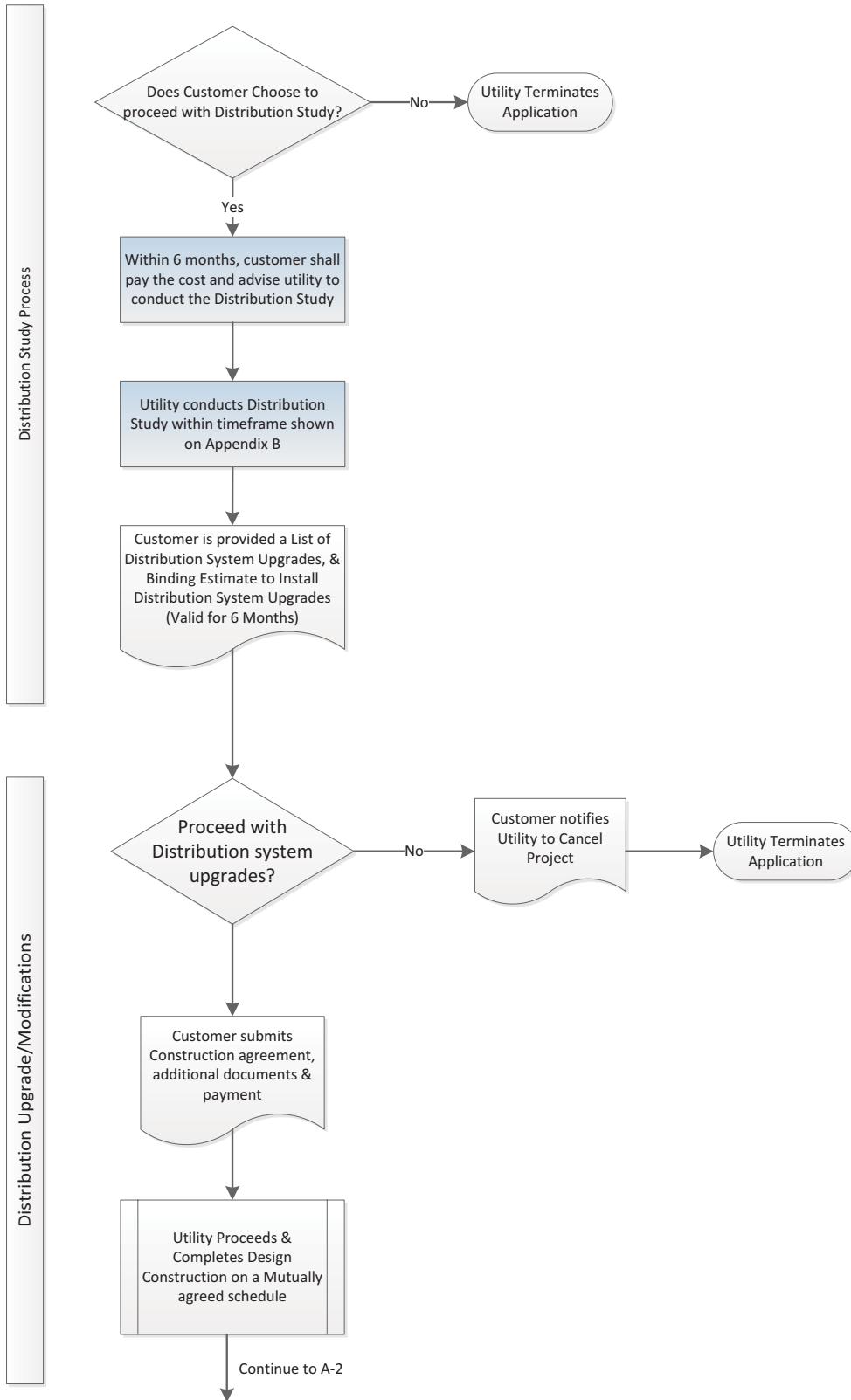

Appendix B-Interconnection & Net Metering Costs and Timelines

Interconnection Table – Applicant Costs

	Application Review	Engineering Review	Distribution Study	Distribution Upgrades	Testing & Inspection
Category 2	\$100	\$0	Propose fixed fee	Actual or Max Approved by Commission	Proposed Fixed fee

Combined Net Metering / Interconnection Table - Applicant Costs

	Net Meter Program Fee	Application Review	Engineering Review	Distribution Study	Distribution Upgrades	Testing & Inspection
Category 2	\$25	\$75	\$0	Propose fixed fee	Actual or Max Approved by Commission	\$0

Interconnection Timeline – Working Days

	Application Complete	Application Review	Engineering Study Completion	Distribution Study Completion	Distribution Upgrades	Testing & Inspection
Category 2	10 days	10 days	10 days	10 days	Mutually Agreed	10 days to notify of scheduled visit

Appendix C- Definitions

Aggregate Generator Output: The total nameplate generation stated in AC kW for a given application.

Alternative electric supplier (AES): as defined in section 10g of 2000 PA 141, MCL 460.10g

Alternative electric supplier net metering program plan: document supplied by an AES that provides detailed information to an applicant about the AES's net metering program.

Applicant: Legally responsible person applying to an Electric Utility to interconnect a project with the Electric Utility's distribution system or a person applying for a net metering program. An applicant shall be a customer of an Electric Utility and may be a customer of an AES.

Application Review: Review by the Electric Utility of the completed application for interconnection to determine if an engineering review is required.

Area Network: A location on the distribution system served by multiple transformers interconnected in an electrical network circuit.

Category 1: An inverter based project of 20kW or less that uses equipment certified by a nationally recognized testing laboratory to IEEE 1547.1 testing standards et seq

Category 2: A project of greater than 20 kW and not more than 150 kW, and projects less than or equal to 20kW which do not meet the criteria for Category 1 projects.

Category 3: A project of greater than 150 kW and not more than 550 kW.

Category 4: A project of greater than 550 kW and not more than 2 MW.

Category 5: A project of greater than 2 MW.

Certified equipment: A generating, control, or protective system that has been certified as meeting acceptable safety and reliability standards by a nationally recognized testing laboratory in conformance IEEE1547.1 et seq.

Commission: The Michigan Public Service Commission

Commissioning test: The procedure, performed in compliance with IEEE 1547.1, for documenting and verifying the performance of a project to confirm that the project operates in conformity with its design specifications.

Customer: A person who receives electric service from an Electric Utility's distribution system or a person who participates in a net metering program through an AES or Electric Utility.

Customer-generator: A person that uses a project on-site that is interconnected to an Electric Utility distribution system.

Distribution system: The structures, equipment, and facilities owned and operated by an Electric Utility to deliver electricity to end users, not including transmission facilities that are subject to the jurisdiction of the federal energy regulatory commission.

Distribution system study: A study to determine if a distribution system upgrade is needed to accommodate the proposed project and to determine the cost of an upgrade if required.

Electric provider: Any person or entity whose rates are regulated by the commission for selling electricity to retail customers in the state.

Electric Utility: Term as defined in section 2 of 1995 PA 30, MCL 460.562.

Engineering Review: A study to determine the suitability of the interconnection equipment including any safety and reliability complications arising from equipment saturation, multiple technologies, and proximity to synchronous motor loads.

Flow-back: An installed electric generation project which operates in parallel with an Electric Utility which is capable of providing energy flow to the Utility without an installed relay protection scheme and isolating device preventing energy flow to the Utility.

IEEE: Institute of Electrical and Electronics Engineers

IEEE 1547 et seq: IEEE ‘Standard for Interconnecting Distributed Resources with Electric Power Systems,’ dated January 1, 2003.

IEEE 1547.1 et seq: IEEE ‘Standard Conformance Test Procedures for Equipment Interconnecting Distributed Resources with Electric Power Systems,’ dated January 1, 2005.

Interconnection: The process undertaken by an Electric Utility to construct the electrical facilities necessary to connect a project with a distribution system so that parallel operation can occur.

Interconnection procedures: The requirements that govern project interconnection adopted by each electric utility and approved by the commission.

kW: kilowatt

kWh: kilowatt-hours

Material modification: A modification that changes the maximum electrical output of a project or changes the interconnection equipment including but not limited to the following:

- Changing from certified to non certified equipment

- Replacing a component with a component of different functionality or UL listing.

MW: megawatt

Nationally recognized testing laboratory: A testing laboratory recognized by the accreditation program of the U.S. Department of Labor Occupational Safety and Health Administration.

Non-Flow Back: An installed electric generation project which operates in parallel with the Electric Utility with a relay protection scheme and isolation device preventing power flow back to the Utility.

Parallel Operating Agreement: An agreement between the Utility and the Customer governing the parallel operation of the generation equipment. Parallel Operating Agreement will cover matters customarily addressed in such agreements in accordance with Good Utility Practice, including, without limitation, system operation, interconnection rate, defaults and remedies, and liability

Parallel operation: The operation, for longer than 100 milliseconds, of a project while connected to the energized distribution system.

Point of Common Coupling (PCC): The point where the facilities that deliver electric power to the load (Electric Utility) meets the facility contained within a single premises or group of premises that deliver electric power to the load (Electric Utility customer).

Project: Electrical generating equipment and associated facilities which are eligible for interconnection to the Electric Utility that are not owned or operated by an Electric Utility.

Project Developer: Single point of contact for the Applicant. The Project Developer may also be the Applicant and/or Customer.

Renewable energy credit (REC): A credit granted pursuant to the commission's renewable energy credit certification and tracking program in section 41 of 2008 PA 295, MCL 460.1041.

Renewable energy resource: Term as defined in section 11(i) of 2008 PA 295, MCL 460.1011(i)

Renewable energy system: Term as defined in section 11(k) of 2008 PA 295, MCL 460.1011(k).

Spot network: A location on the distribution system that uses 2 or more inter-tied transformers to supply an electrical network circuit.

UL 1741: The 'Standard for Inverters, Converters, Controllers and Interconnection System Equipment for Use With Distributed Energy Resources', November 7, 2005 revision.

UL 1741 scope 1.1A: Paragraph 1.1A contained in chapter 1, section 1 of UL 1741, effective May 7, 2007.

Uniform interconnection application form: The standard application forms, approved by the commission under R 460.615 and used for category 1, category 2, category 3, category 4, and category 5 projects.

Uniform interconnection agreement: The standard interconnection agreements approved by the commission under R 460.615 and used for category 1, category 2, category 3, category 4, and category 5 projects.

Uniform net metering application: The net metering application form approved by the commission under R 460.642 and used by all electric utilities and AES.

Working days: Days excluding Saturdays, Sundays, Holidays and other days when the offices of the Electric Utility are not open to the public.

Appendix D-Sample Site Plan

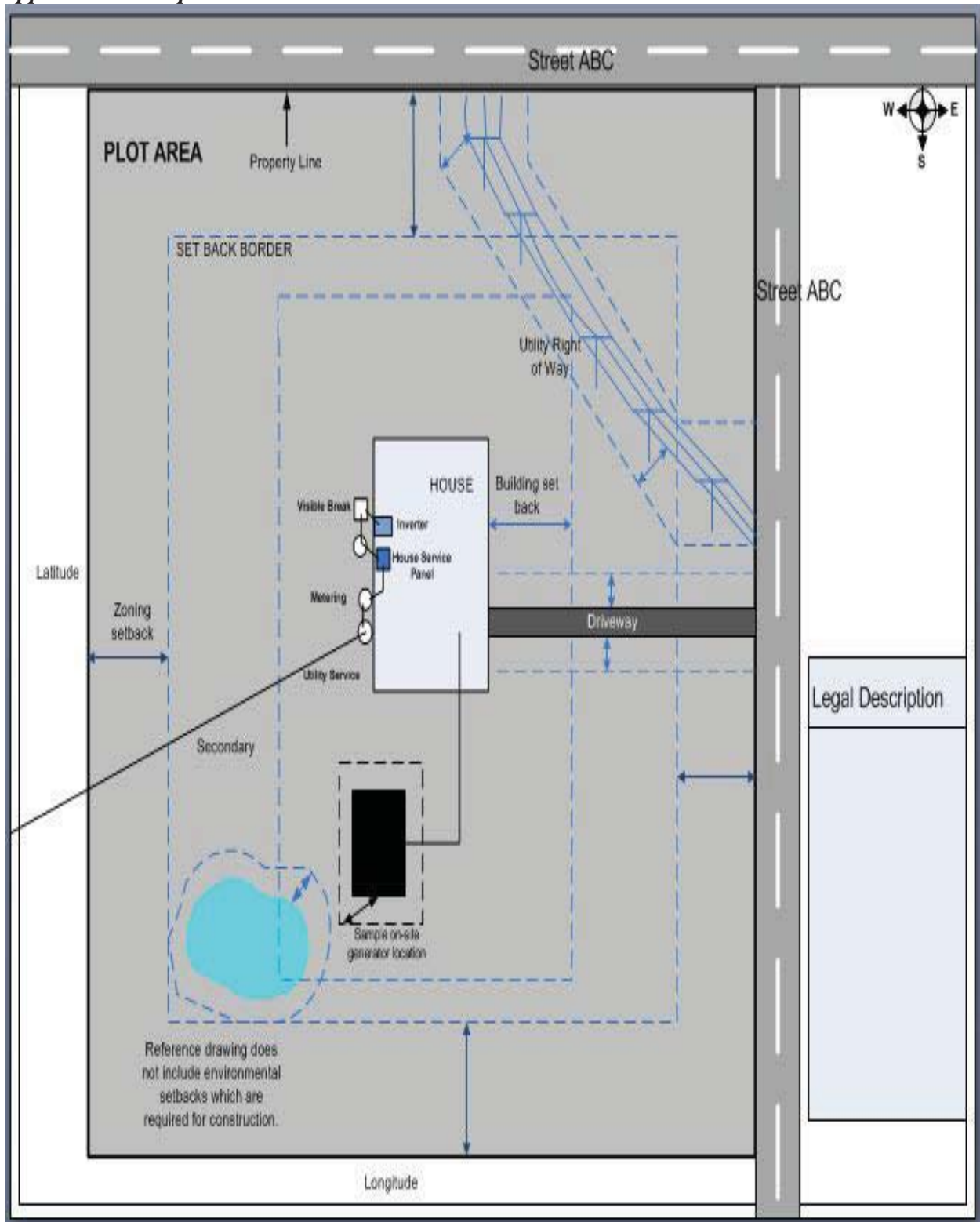

Appendix E-Sample One-Line Synchronous Projects

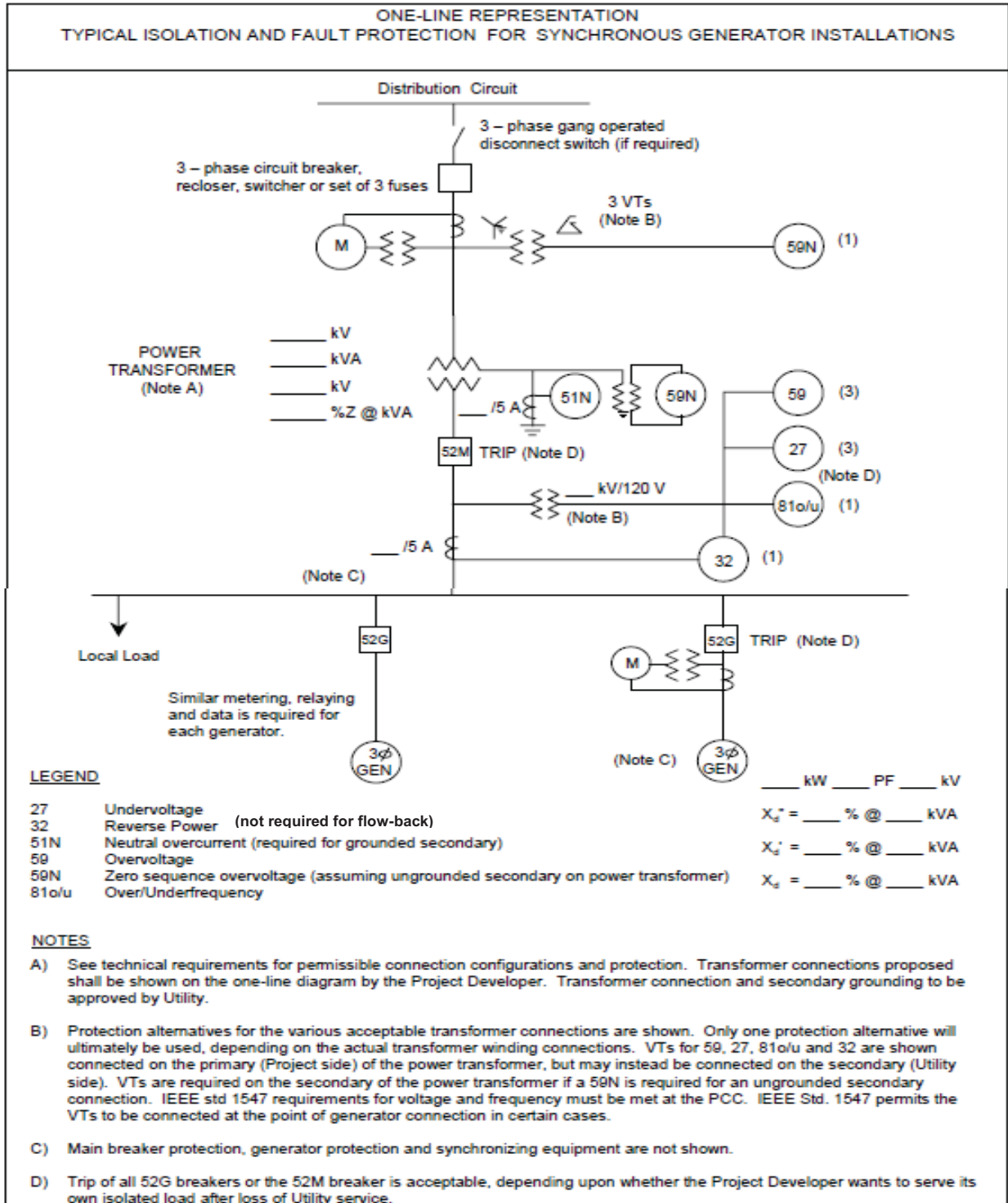

Instructions: Attach data sheets as required. Indicate in the table below the page number of the attached data (manufacturer's data where appropriate) on which the requested information is provided. Provide one table for each unique generator.

Item No	Data Value	Data Description	Attached Page No
1		Generator Type (synchronous or induction)	
2		Generator Nameplate Voltage	
3		Generator Nameplate Watts or Volt-Amperes	
4		Generator Nameplate Power Factor (pf)	
5		Direct axis reactance (saturated)	
6		Direct axis transient reactance (saturated)	
7		Direct axis sub-transient reactance (saturated)	
8		Short Circuit Current contribution from generator at the Point of Common Coupling (single-phase and three-phase	
9		National Recognized Testing Laboratory Certification	
10		Written Commissioning Test Procedure	

Appendix F-Sample One-Line Induction Projects

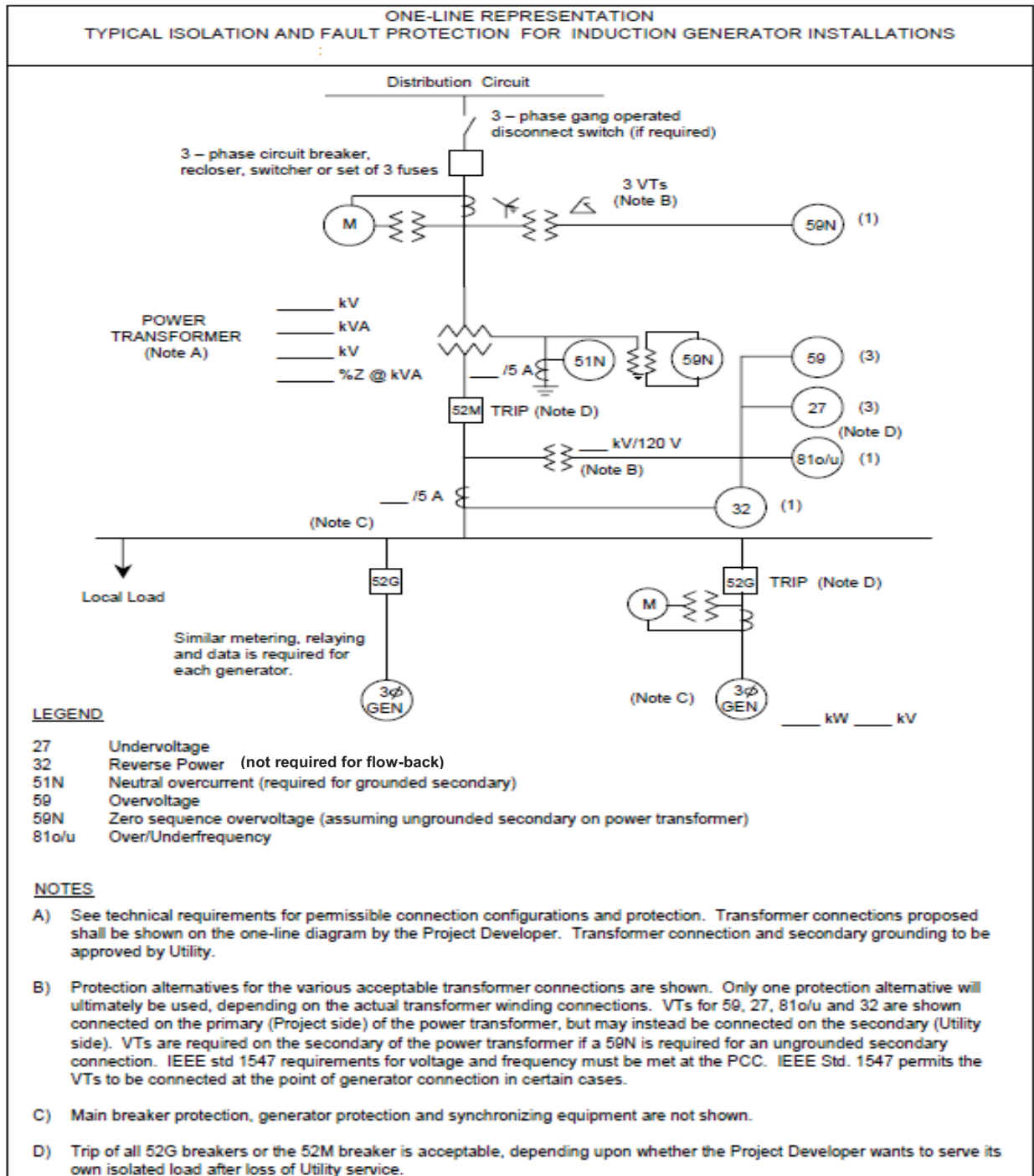

Instructions: Attach data sheets as required. Indicate in the table below the page number of the attached data (manufacturer's data where appropriate) on which the requested information is provided. Provide one table for each unique generator.

Induction Electric Generator(s) at the Project:**Generator No _____**

Item No	Data Description	Attached Page No
1	Generator Type (Inverter)	
2	Generator Nameplate Voltage	
3	Generator Nameplate Watts or Volt-Amperes	
4	Generator Nameplate Power Factor (pf)	
5	Short Circuit Current contribution from generator at the Point of Common Coupling (single-phase and three-phase)	
6	National Recognized Testing Laboratory Certification	
7	Written Commissioning Test Procedure	

Appendix G-Sample One-Line Inverter Projects

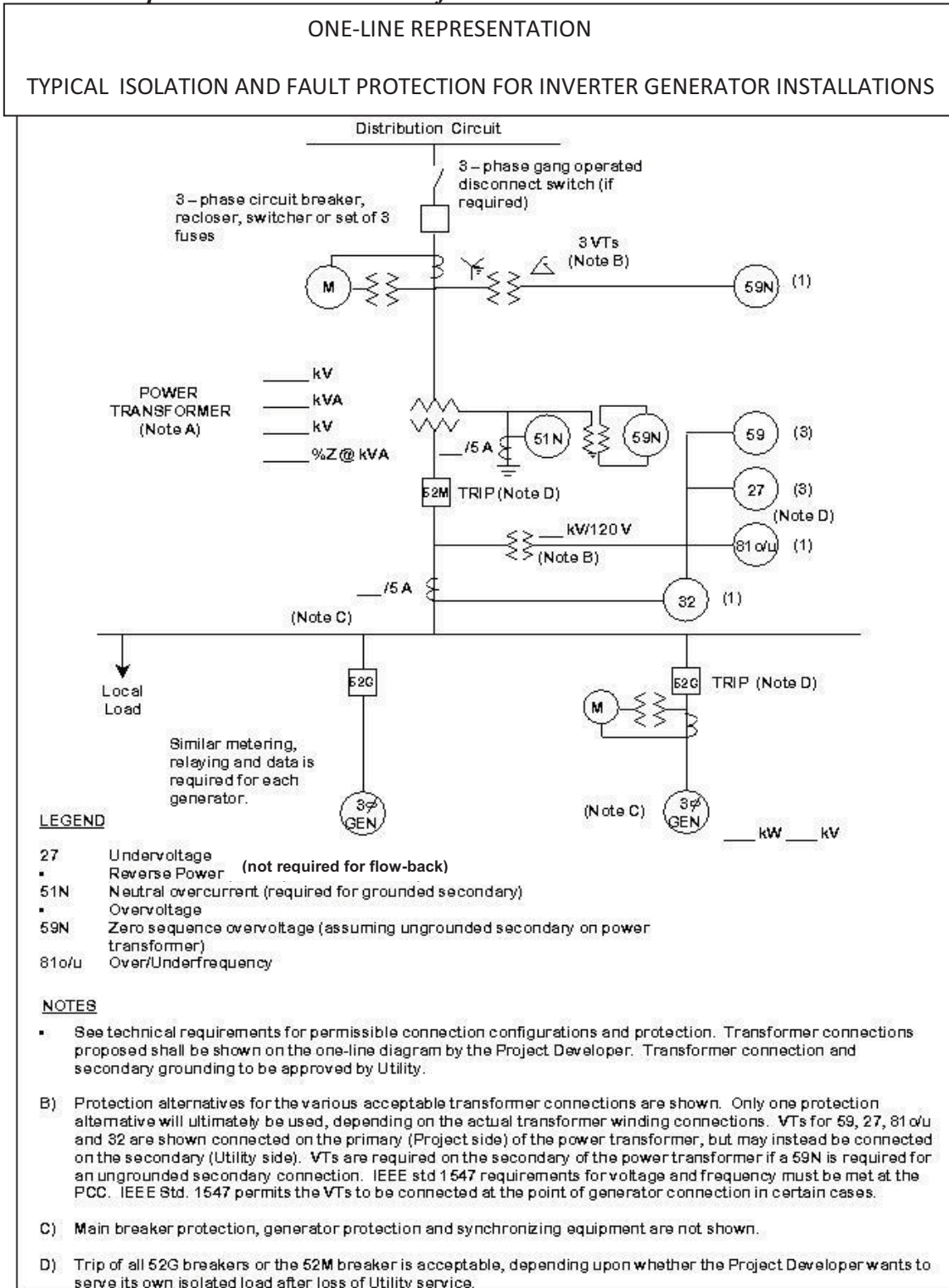

C-1

Instructions: Attach data sheets as required. Indicate in the table below the page number of the attached data (manufacturer's data where appropriate) on which the requested information is provided. Provide one table for each unique generator.

Inverter Electric Generator(s) at the Project:**Generator No _____**

Item No	Data Description	Attached Page No
1	Generator Type (Inverter)	
2	Generator Nameplate Voltage	
3	Generator Nameplate Watts or Volt-Amperes	
4	Generator Nameplate Power Factor (pf)	
5	Short Circuit Current contribution from generator at the Point of Common Coupling (single-phase and three-phase)	
6	National Recognized Testing Laboratory Certification	
7	Written Commissioning Test Procedure	

Appendix H-Sample One-Line Diagram for Non-Flow Back Projects

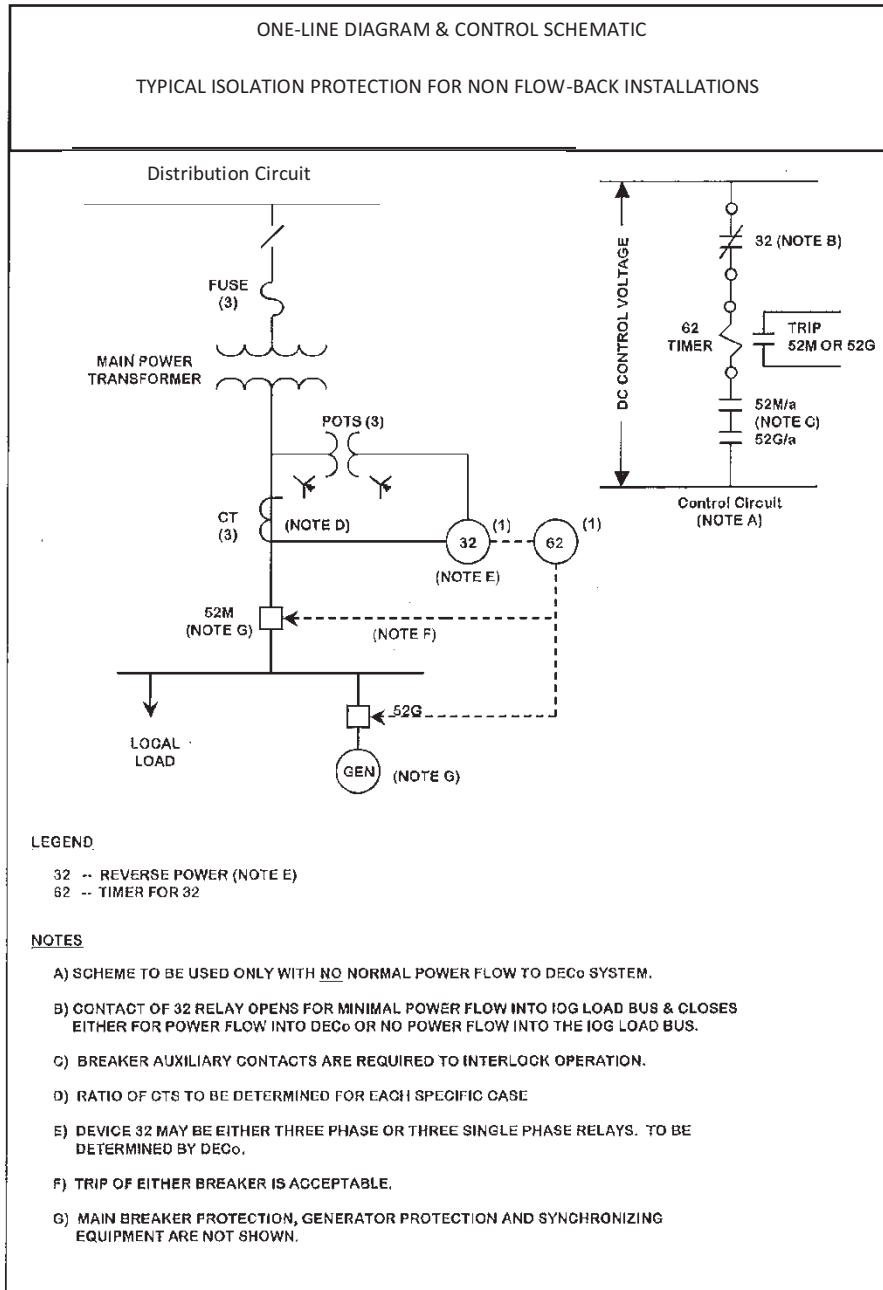

Appendix I-Sample One-Line Diagram for Flow-Back Projects

