

MICHIGAN ELECTRIC UTILITY

Generator Interconnection Procedures

***Category 1 Inverter Based
Projects with
Aggregate Generator Output
20 kW or Less certified for anti-islanding in
compliance with IEEE 1547 standards et seq***

December 2012

Introduction

Category 1

This Generator Interconnection Procedure document outlines the process & requirements used to install or modify certified inverter based generation projects with aggregate generator output capacity ratings less than or equal to 20kW and designed to operate in parallel with the Utility electric system. Technical requirements are defined according to type of generation, location of the interconnection, and mode of operation (Flow-back or Non-Flow-back). The process is designed to allow for a reasonably expeditious interconnection to the Utility electric system that is both safe and reliable.

This document has been filed with the Michigan Public Service Commission (MPSC) and complies with rules established for the interconnection of parallel generation to the Utility electric system in the MPSC Order in Case No. U-15787.

The term “Project” will be used throughout this document to refer to electric generating equipment and associated facilities that are not owned or operated by an Electric Utility. The term “Project Developer” means a person that owns, operates, or proposes to construct, own, or operate, a Project. Project Developer may be also be the Applicant.

This document does not address other Project concerns such as environmental permitting, local ordinances, or fuel supply. Nor does it address agreements that may be required with the Utility, an Alternate Electric Supplier, and/or the transmission provider, or state or federal licensing, to market the Project’s energy. An interconnection request does not constitute a request for transmission or establishment/modification of existing electrical lines or electric service.

When requested by the Project Developer, it may be possible for the Utility to adjust requirements stated herein on a case-by-case basis. The review necessary to support such adjustments, however, may be extensive and may exceed the ordinary costs and timeframes addressed in these requirements. Therefore, if requested by the Project Developer, adjustments to these requirements will only be considered if the Project Developer agrees in advance to compensate the Utility for the actual and reasonably and prudently incurred added costs that are not otherwise recovered, if any, of the additional reviews, and to also allow the utility a reasonable amount of additional time for the additional reviews.

The Utility may apply for a technical waiver from one or more provisions of these rules and the MPSC may grant a waiver.

Non-Certified Inverter based, synchronous, or induction generation projects less than or equal to 20kW will be implemented under the Category 2 procedures and applications.

Table of Contents

INTERCONNECTION PROCESS.....	4
<i>Customer Project Planning Phase</i>	4
<i>Application</i>	4
<i>Application Review</i>	4
<i>Customer Install & Parallel Operating Agreement (POA)</i>	5
<i>Meter Install, Testing, & Inspection</i>	5
<i>Operation in Parallel</i>	6
OPERATIONAL PROVISIONS.....	6
<i>Disconnection</i>	6
<i>Maintenance and Testing</i>	6
TECHNICAL REQUIREMENTS.....	7
<i>Major Component Design Requirements</i>	7
<i>Data</i>	7
<i>Isolation Device</i>	8
<i>Interconnection Lines</i>	8
RELAYING DESIGN REQUIREMENTS.....	8
<i>Momentary Paralleling</i>	8
<i>Automatic Reclosing</i>	9
<i>Single-Phase Sectionalizing</i>	9
REQUIREMENTS FOR INVERTER PROJECTS.....	9
<i>Inverter Projects</i>	9
<i>Synchronous, Induction, Non-Certified Inverter Projects</i>	9
<i>Relay Setting Criteria</i>	9
MAINTENANCE AND TESTING.....	9
<i>Installation Approval</i>	10
MISCELLANEOUS OPERATIONAL REQUIREMENTS.....	10
<i>Operating in Parallel</i>	10
<i>Reactive Power Control</i>	11
<i>Site Limitations</i>	12
REVENUE METERING REQUIREMENTS.....	12
<i>Non Flow-back Projects</i>	12
<i>Flow-back Projects</i>	12
APPENDIX A-INTERCONNECTION PROCESS FLOW DIAGRAM.....	14
APPENDIX B-INTERCONNECTION & NET METERING COSTS AND TIMELINE.....	15
APPENDIX C-DEFINITIONS.....	16
APPENDIX D-SAMPLE SITE PLAN.....	20
APPENDIX E-SAMPLE ONE-LINE DIAGRAM FOR FLOW-BACK INVERTER BASED PROJECTS.....	21
APPENDIX F-SAMPLE ONE-LINE DIAGRAM FOR NON-FLOW BACK PROJECTS.....	21
APPENDIX G-SAMPLE PERIODIC TEST LOG.....	23
APPENDIX H-ISOLATION DEVICE.....	24
APPENDIX I-ISOLATION TRANSFORMER.....	25

Interconnection Procedures

Interconnection Process

Customer Project Planning Phase

An applicant may contact the Utility before or during the application process regarding the project. The Utility can be reached by phone, e-mail, or by the external website to access information, forms, rates, and agreements. A Utility will provide up to 2 hours of technical consultation at no additional cost to the applicant. Consultation may be limited to providing information concerning the Utility system operating characteristics and location of system components.

Application

The Project Developer must first submit an Interconnection application or a Combined Interconnection and Net Metering application to the Utility. A separate application is required for each Project or Project site. The blank Interconnection Application or Combined Interconnection and Net Metering application can be found on the Electric Utility's website (insert link) .

An applicant shall complete a submittal of required interconnection application and Interconnection filing fee per the table in Appendix B. The Utility will notify the Project Developer within 10 business days of receipt of an Interconnection Application. If any portion of the Interconnection Application, data submittal (a site plan and the one-line diagrams), or filing fee is incomplete and/or missing, the Utility will return the application, data, and filing fee to the Project developer with explanations. Project Developer will need to resubmit the application with all the missing items.

Once the Utility has accepted the combined Interconnection and Net Metering Application, an identifying number will be assigned to the Project. The Utility will then advise the applicant that the application is complete and provide the customer with the identifying number.

Application Review

Upon receipt of payment of the Category 1 Interconnection Application fee of \$75, the Utility will review the complete application for interconnection to determine if additional Study(ies)^{1,2}

Engineering Review¹

The Utility shall study the project to determine the suitability of the interconnection equipment including safety and reliability complications arising from equipment saturation, multiple technologies, and proximity to synchronous motor loads. The electric utility shall provide in writing the results of the engineering study within the time indicated in the notification. The customer is exempt from the cost of the study except with respect to any study costs that may be included in and applicable to the customer through the Company's general tariff rates for the relevant customer class. If an engineering review determines that a distribution study is not required, the project will advance to the Meter Install, Testing, & Inspection phase of the process.

are required. The Utility will notify the Project Developer within 10 business days of receipt of a complete application and if additional study(ies) are required. The applicant shall provide any changes or updates to the application before additional Study(ies) begin. The Utility may request additional data be submitted as necessary during the review phase to clarify the operation of the Project. If the additional study(ies) are not required, the Utility will notify the Project Developer of its preliminary approval or disapproval of the interconnection. If approved, the project will advance to the Meter Install, Testing, & Inspection phase of the process. If the interconnection is disapproved, the utility shall notify the applicant of the necessary corrective actions required for approval. The applicant, after taking corrective action, may request the electric utility to reconsider the interconnection request.

Customer Install & Parallel Operating Agreement (POA)

The applicant shall notify the Electric Utility when an installation and any required local code inspection and approval is complete. The Parallel Operating Agreement for customer owned generation which operates in parallel with the Electric Utility may be accessed on the Electric Utility's website. The Parallel Operating Agreement will cover matters customarily addressed in such agreements in accordance with Good Utility Practice, including, without limitation, system operation, interconnection rate, defaults and remedies, and liability. The applicant shall complete, sign and return the POA to the Utility. Any delay in the applicant's execution of the Interconnection and Operating Agreement will not toll the interconnection deadlines.

Meter Install, Testing, & Inspection

Upon receipt of the local code inspection approval and POA executed by the applicant, the Utility will schedule the meter install, testing, and inspection³. The Utility shall have an opportunity to schedule a visit to witness and perform commissioning tests required by IEEE 1547 et seq. and inspect the project. The Electric Utility may provide a waiver of its right to visit the site to inspect the project and witness or perform the commissioning tests. The Utility shall notify the applicant of its intent to visit the site, inspect the project, witness or perform the commissioning tests, or of its intent to waive inspection within 10 working days after notification that the installation and local code inspections have passed. Within 5 working days from receipt of the completed commissioning test report (if applicable), the Utility will notify the applicant of

Distribution Study²

The Utility shall study the project to determine if a distribution system upgrade is needed to accommodate the proposed project and determine the cost of an upgrade if required. The applicant is exempt from the cost of the study and upgrades if required, except with respect to any distribution study costs that may be included in and applicable to the customer through the Company's general tariff rates for the relevant customer class. The electric utility shall provide in writing the results of the distribution study including estimated completion timeframe for the upgrades, if required, to the applicant, within the timeframe indicated in the notification. If a distribution study determines that a distribution upgrades are not required, the project will advance to the Meter Install, Testing, & Inspection phase of the process.

³ If the Distribution Study determines that distribution upgrades are required, the meter install will follow the completion of the distribution upgrades. The applicant is exempt from the cost of the upgrades if required, except with respect to any distribution costs that may be included in and applicable to the customer through the Company's general tariff rates for the relevant customer class.

its final approval or disapproval of the interconnection. The utility's review is limited to determining whether the project was constructed consistent with the previously approved application and satisfactory completion of the commissioning test (as applicable). If the project was constructed consistent with the application and passes the commissioning test, then the project shall be awarded final approval for parallel operation and the Utility will execute the POA or otherwise approve operation. If the project was not constructed consistent with the application or does not pass the commissioning test, the utility may deny final approval for parallel operation. If the electric utility does not award final approval for the interconnection, the utility shall notify the applicant of the necessary corrective actions required for approval. The applicant, after taking corrective action, may request the electric utility to reconsider the interconnection request.

Operation in Parallel

Upon Utility approval of the interconnection, the Electric Utility shall install required metering, provide to the applicant a written statement of final approval, and a fully executed POA authorizing parallel operation.

Operational Provisions

Disconnection

An Electric Utility may refuse to connect or may disconnect a project from its distribution system if any of the following conditions apply:

- a. Applicant has not complied with any one of the technical requirements contained in the applicable Interconnection Procedures,
- b. The electrical characteristics of the Applicant Facility are not compatible with the electrical characteristics of Utility's distribution system,
- c. An emergency condition exists on Utility's distribution system,
- d. Applicant's protective relay equipment fails,
- e. Utility determines that the Applicant Facility is disrupting service to any Utility Customer,
- f. Disconnection is required to allow for construction, installation, maintenance, repair, replacement, removal, investigation, inspection or testing of any part of Utility's facilities,
- g. If a required installation fails or becomes incapacitated and is not repaired in a timely manner, as determined by Utility
- h. Applicant commits a material breach of the POA

Maintenance and Testing

The Utility reserves the right to test the relaying and control equipment that involves protection of the Utility's electric system, at its sole expense, whenever the Utility determines a need for such testing exists.

The applicant is solely responsible for conducting and documenting proper periodic maintenance on the generating equipment and its associated control, protective equipment, interrupting devices, and main Isolation Device⁴, per manufacturer recommendations.

Routine and maintenance checks of the relaying and control equipment must be conducted in accordance with provided written test procedures which are required by IEEE Std. 1547, and test reports of such testing shall be maintained by the applicant and made available for Utility inspection upon request. [NOTE – IEEE 1547 requires that testing be conducted in accordance with written test procedures, and the nationally recognized testing laboratory providing certification will require that such test procedures be available before certification of the equipment.]

Technical Requirements

The following discussion details the technical requirements for interconnection of Category 1 IEEE 1547 et seq Certified Inverter Based generation Projects 20 kW or less. For Projects within this capacity rating range, the Utility has made a significant effort to simplify the technical requirements. This effort has resulted in adoption of IEEE Standard 1547, Standard for Interconnecting Distributed Resources with Electric Power Systems, being incorporated herein by reference. All protective functions are compliant with IEEE Standard 1547 et seq.

Certain requirements, as specified by this document, must be met to provide compatibility between the Project and the Utility's electric system, and to assure that the safety and reliability of the electric system is not degraded by the interconnection. The Utility reserves the right to evaluate and apply newly developed protection and/or operation schemes at its discretion. In addition, the Utility reserves the right to evaluate Projects on an ongoing basis as system conditions change, such as circuit loading, additional generation placed online, etc. The Utility shall bear the full cost of any changes to its distribution system resulting from such evaluations and applications.

Upgraded revenue metering may be required for the Project.

Major Component Design Requirements

The data requested in Appendix E, or F for all major equipment and relaying proposed by the Project Developer, must be submitted as part of the initial application for review and approval by the Utility. The Utility may request additional data be submitted as necessary during the Engineering Review and/or Distribution Study phase to clarify the operation of the Project.

Once installed, the interconnection equipment must be reviewed and approved by the Utility prior to being connected to the Utility's electric system and before Parallel Operation is allowed.

Data

The data that the Utility requires to evaluate the proposed interconnection is documented on a one-line diagram by generator type in Appendices E, or F.

⁴ Main Isolation Device – When required by the Electric Utility operating practices, a readily accessible, lockable, visible-break isolation device located between the Electric Utility and the Project.

A site plan, one-line diagrams, and interconnection protection system details of the Project are required as part of the application data. The generator manufacturer supplied data package should also be supplied.

Isolation Device

After review, the isolation device may not be required by the Utility. If required and/or installed, this device⁵ would be placed at the Point of Common Coupling (PCC) and must meet all of the requirements of Appendix H.

Interconnection Lines

Any new distribution service line construction to connect the Project to the Utility's electric system will be undertaken by the Utility at the Project Developer's expense. The new line(s) will terminate on a utility approved structure provided by and paid for by the Project Developer.

The physically closest available system voltage, as well as equipment and operational constraints influence the chosen point of interconnection. The Utility has the ultimate authority to determine the acceptability of a particular PCC.

Relaying Design Requirements

Regardless of the technology of the interconnection, for simplicity for all Projects in this capacity rating range, the interconnection relaying system must be certified by a nationally recognized testing laboratory to meet IEEE Std. 1547 et seq. The data submitted for review must include information from the manufacturer indicating such certification, and the manufacturer must placard the equipment such that a field inspection can verify the certification. A copy of this standard may be obtained (for a fee) from the Institute of Electrical and Electronics Engineers (www.ieee.org).

If the protective system uses AC power as the control voltage, it must be designed to disconnect the generation from the Utility electric system if the AC control power is lost. Utility will work with Project Developer for system design for this requirement.

Momentary Paralleling

For situations where the Project will only be operated in parallel with the Utility's electric system for a short duration (100 milliseconds or less), as in a make-before-break automatic transfer scheme, no additional relaying is required. Such momentary paralleling requires a modern integrated Automatic Transfer Switch (ATS) system, which is incapable of paralleling the Project with the Utility's electric system. The ATS must be tested, verified, and documented by the Project Developer for proper operation at least every 2 years. The Utility may be present during this testing.

⁵ Isolation Device -A rackable circuit breaker, circuit switcher, pole top switch, load-break disconnect, etc., depending on the electrical system configuration.

Automatic Reclosing

The Utility employs automatic multiple-shot reclosing on most of the Utility's circuit breakers and circuit reclosers to increase the reliability of service to its customers. Automatic single-phase overhead reclosers are regularly installed on distribution circuits to isolate faulted segments of these circuits.

The Project Developer is advised to consider the effects of Automatic Reclosing (both single phase and three phase) to assure that the Project's internal equipment will not be damaged. In addition to the risk of damage to the Project, an out-of-phase reclosing operation may also present a hazard to Utility equipment since this equipment may not be rated or built to withstand this type of reclosing. The Utility will determine relaying and control equipment that needs to be installed to protect its own equipment from out-of-phase reclosing. Installation of this protection will be undertaken by the Utility at the Utility's expense. The Utility shall not be liable to the customer with respect to damage(s) to the Project arising as a result of Automatic Reclosing.

Single-Phase Sectionalizing

The Utility also installs single-phase fuses and/or reclosers on its distribution circuits to increase the reliability of service to its customers. Three-phase generator installations may require replacement of fuses and/or single-phase reclosers with three-phase circuit breakers or circuit reclosers at the Utility's expense.

Requirements for Inverter Projects

Inverter Projects

No isolation transformer is required between the generator and the secondary distribution connection. If an isolation transformer is used, refer to Appendix I for specific requirements.

Synchronous, Induction, Non-Certified Inverter Projects

Non-IEEE 1547 et seq Certified Inverter, Synchronous, or Induction generation projects with an Aggregate Generation output of 20kW or less operating in parallel with the Electric Utility shall apply for interconnection under the Category 2 Procedures and Applications.

Relay Setting Criteria

The relay settings for Projects 20 kW or less must conform to the values specified in IEEE Std. 1547 et seq.

Maintenance and Testing

The Utility reserves the right to test the relaying and control equipment that involves protection of the Utility's electric system whenever the Utility determines a reasonable need for such testing exists.

The Project Developer is solely responsible for conducting and documenting proper periodic maintenance on the generating equipment and its associated control, protective equipment, interrupting devices, and main Isolation Device, per manufacturer recommendations.

The Project Developer is solely responsible for routine and maintenance checks of the relaying and control equipment that must be conducted in accordance with provided written test procedures which are required by IEEE Std. 1547 et seq, and test reports of such testing shall be maintained by the Project Developer and made available for Utility inspection upon request.

[NOTE – IEEE 1547 requires that testing be conducted in accordance with written test procedures, and the nationally recognized testing laboratory providing certification will require that such test procedures be available before certification of the equipment.]

Periodic test reports or a log for inspection shall be maintained and provided to the Utility upon written request. See Appendix G ‘Periodic Interconnection Test Log’

Installation Approval

The Project Developer must provide the Utility with at least 5 business days advance written notice of when the Project will be ready for inspection, testing, and approval.

Prior to final approval for Parallel Operation, the Utility reserves the right to inspect the Project and require action to assure conformance to the requirements stated herein.

Miscellaneous Operational Requirements

Miscellaneous requirements include synchronizing equipment for Parallel Operation, reactive requirements, and system stability limitations.

Operating in Parallel

The Project Developer will be solely responsible for the required synchronizing equipment and for properly synchronizing the Project with the Utility’s electric system.

Voltage fluctuation at the Point of Common Coupling (PCC) during synchronization is limited per IEEE Std. 1547 et seq.

These requirements are directly concerned with the actual operation of the Project with the Utility:

- The Project may not commence parallel operation until final approval has been given by the Utility. The completed installation is subject to inspection by the Utility prior to final approval. Preceding this inspection, all contractual agreements must be executed by the Project Developer.
- The Project must be designed to prevent the Project from energizing into a de-energized Utility line. The Project’s circuit breaker or contactor must be blocked from closing in on a de-energized Electric Utility’s distribution system.

- The Project shall discontinue parallel operation with a particular service and perform necessary switching when requested by the Utility for any of the following reasons:
 1. When public safety is being jeopardized.
 2. During voltage or loading problems, system emergencies, or when abnormal sectionalizing or circuit configuration occurs on the Utility system.
 3. During scheduled shutdowns of Utility equipment that are necessary to facilitate maintenance or repairs.
 4. In the event there is demonstrated electrical interference (i.e. Voltage Flicker, Harmonic Distortion, etc.) to the Utility's customers, suspected to be caused by the Project, and such interference exceeds then current system standards, the Utility reserves the right, to install special test equipment as may be required to perform a disturbance analysis and monitor the operation and control of the Project to evaluate the quality of power produced by the Project. In the event that no standards exist, then the applicable tariffs and rules governing electric service shall apply. If the Project is the source of the interference, and that interference exceeds the Utility's standards or generally accepted industry standards, then it shall be the responsibility of the Project Developer to eliminate the interference problem.
 5. When either the Project or its associated synchronizing and protective equipment is demonstrated by the Utility to be improperly maintained, so as to present a hazard to the Utility system or its customers.
 6. Whenever the Project is operating isolated with other Utility customers, for whatever reason.
 7. Whenever the Utility notifies the Project Developer in writing of a non-safety related violation of the Interconnection Agreement and the Project Developer fails to remedy the violation within ten working days of notification.

If the Project has shown an unsatisfactory response to requests to separate the generation from the Utility system, the Utility reserves the right to disconnect the Project from parallel operation with the Utility electric system until all operational issues are satisfactorily resolved.

Reactive Power Control

Inverter- Projects that will operate in the Flow-back Mode must provide for their own reactive needs (steady state unity power factor at the Point of Receipt). To obtain unity power factor, the Inverter Project can:

1. Install a switchable Volt-Ampere reactive (VAR) supply source to maintain unity power factor at the Point of Receipt; or
2. Provide the Utility with funds to install a VAR supply source equivalent to that required for the Project to attain unity power factor at the Point of Receipt at full output.

There are no interconnection reactive power capability requirements for Inverter Projects that will operate in the Non-Flow-back Mode. The Utility's existing rate schedules, incorporated herein by reference, contain power factor adjustments based on the power factor of the metered load at these facilities.

Site Limitations

The Project Developer is responsible for evaluating the consequences of unstable generator operation or voltage transients on the Project equipment and determining, designing, and applying any relaying which may be necessary to protect that equipment. This type of protection is typically applied on individual generators to protect the generator facilities.

The Utility will determine if operation of the Project will create objectionable voltage flicker and/or disturbances to other Utility customers and develop any required mitigation measures at the Project Developer's expense.

Revenue Metering Requirements

The Utility will own, operate, and maintain all required billing metering equipment. An electric provider serving over 1,000,000 customers shall provide a meter or meters capable of measuring the flow of energy in both directions at the Electric Utility's cost. If the customer's meter is not capable of reverse registration, an electric provider serving less than 1,000,000 customers shall provide a meter or meters capable of measuring the flow of energy in both directions at the customer's cost.

Non Flow-back Projects

A Utility meter will be installed that only records energy deliveries to the Project.

Flow-back Projects

The Project Developer shall provide the Utility access to the premises at reasonable times to install, turn on, disconnect, inspect, test, read, repair, or remove the metering equipment. The Project Developer may, at its option, have a representative witness this work.

The metering installations shall be constructed in accordance with the practices, which normally apply to the construction of metering installations for residential, commercial, or industrial customers. For Projects with multiple generators, metering of each generator may be required. When practical, multiple generators may be metered at a common point provided the metered quantity represents only the gross generator output.

The Utility shall supply to the Project Developer all required metering equipment and the standard detailed specifications and requirements relating to the location, construction, and access of the metering installation and will provide consultation pertaining to the meter installation as required. The Utility will endeavor to coordinate the delivery of these materials with the Project Developer's installation schedule during normal scheduled business hours.

The Project Developer may be required to provide a mounting surface for the metering equipment. The mounting surface and location must meet the Utility's specifications and requirements.

The Project Developer may be required to install some of the metering equipment on its side of the PCC, including instrument transformers, cabinets, conduits, and mounting surfaces. The Utility shall install the meters and appropriate communication links. The Utility will endeavor to coordinate the installation of these items with the Project Developer's schedule during normal scheduled business hours.

Appendix A-Interconnection Process Flow Diagram

**Category 1 Inverter Based 20 kW and Under Projects
Interconnection Process Flow Diagram**

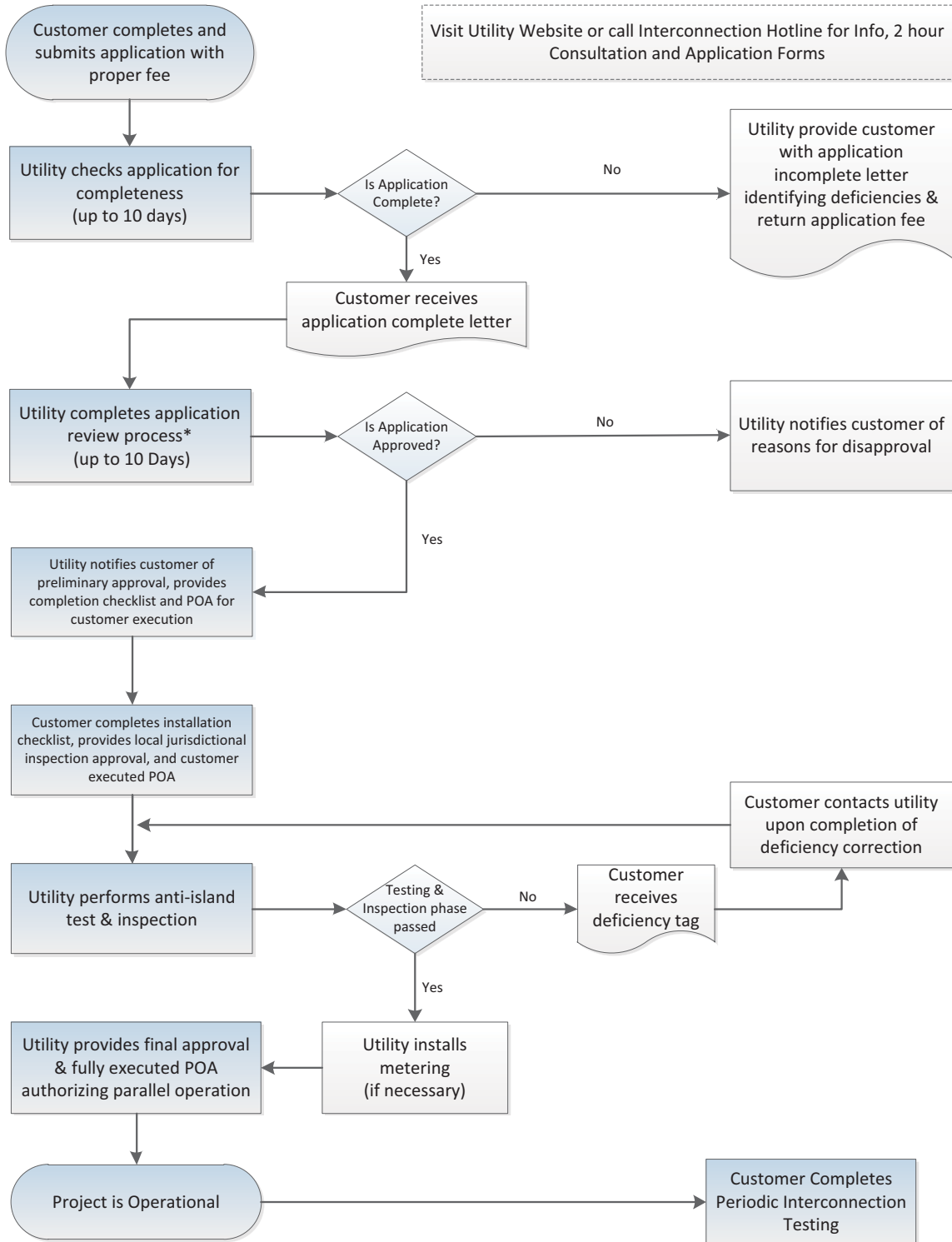

*Application Review Process includes a review for Equipment Saturation or Project Proximity to synchronous motor loads. Remediation may result in additional study time and may result in changes to the distribution system.

Interconnection timeline is provided in Appendix B

Appendix B-Interconnection & Net Metering Costs and Timeline

Interconnection Table – Applicant Costs

	Application Review	Engineering Review	Distribution Study	Distribution Upgrades	Testing & Inspection
Category 1	\$75	\$0	\$0	\$0	\$0

Combined Net Metering / Interconnection Table - Applicant Costs

	Net Meter Program Fee	Application Review	Engineering Review	Distribution Study	Distribution Upgrades	Testing & Inspection
Category 1	\$25	\$75	\$0	\$0	\$0	\$0

Interconnection Timeline – Working Days

	Application Complete	Application Review	Engineering Study Completion	Distribution Study Completion	Distribution Upgrades	Testing & Inspection
Category 1	10	10	Often not applicable / site dependent	Often not applicable / site dependent	Often not applicable / site dependent	10

Appendix C-Definitions

Aggregate Generator Output: The total nameplate generation stated in AC kW for a given application.

Alternative electric supplier (AES): as defined in section 10g of 2000 PA 141, MCL 460.10g

Alternative electric supplier net metering program plan: document supplied by an AES that provides detailed information to an applicant about the AES's net metering program.

Applicant: Legally responsible person applying to an Electric Utility to interconnect a project with the Electric Utility's distribution system or a person applying for a net metering program. An applicant shall be a customer of an Electric Utility and may be a customer of an AES.

Application Review: Review by the Electric Utility of the completed application for interconnection to determine if an engineering review is required.

Area Network: A location on the distribution system served by multiple transformers interconnected in an electrical network circuit.

Category 1: An inverter based project of 20kW or less that uses equipment certified by a nationally recognized testing laboratory to IEEE 1547.1 testing standards et seq.

Category 2: A project of greater than 20 kW and not more than 150 kW, and projects less than or equal to 20kW which do not meet the criteria for Category 1 projects.

Category 3: A project of greater than 150 kW and not more than 550 kW.

Category 4: A project of greater than 550 kW and not more than 2 MW.

Category 5: A project of greater than 2 MW.

Certified equipment: A generating, control, or protective system that has been certified as meeting acceptable safety and reliability standards by a nationally recognized testing laboratory in conformance IEEE1547.1 et seq.

Commission: The Michigan Public Service Commission

Commissioning test: The procedure, performed in compliance with IEEE 1547.1, for documenting and verifying the performance of a project to confirm that the project operates in conformity with its design specifications.

Customer: A person who receives electric service from an Electric Utility's distribution system or a person who participates in a net metering program through an AES or Electric Utility.

Customer-generator: A person that uses a project on-site that is interconnected to an Electric Utility distribution system.

Distribution system: The structures, equipment, and facilities owned and operated by an Electric Utility to deliver electricity to end users,

Distribution system study: A study to determine if a distribution system upgrade is needed to accommodate the proposed project and to determine the cost of an upgrade if required.

Electric provider: Any person or entity whose rates are regulated by the commission for selling electricity to retail customers in the state.

Electric Utility: Term as defined in section 2 of 1995 PA 30, MCL 460.562.

Engineering Review: A study to determine the suitability of the interconnection equipment including any safety and reliability complications arising from equipment saturation, multiple technologies, and proximity to synchronous motor loads.

Flow-back: An installed electric generation project which operates in parallel with an Electric Utility which is capable of providing energy flow to the Utility without an installed relay protection scheme and isolating device preventing energy flow to the Utility.

IEEE: Institute of Electrical and Electronics Engineers

IEEE 1547 et seq: IEEE ‘Standard for Interconnecting Distributed Resources with Electric Power Systems,’ dated January 1, 2003.

IEEE 1547.1 et seq: IEEE ‘Standard Conformance Test Procedures for Equipment Interconnecting Distributed Resources with Electric Power Systems,’ dated January 1, 2005.

Interconnection: The process undertaken by an Electric Utility to construct the electrical facilities necessary to connect a project with a distribution system so that parallel operation can occur.

Interconnection procedures: The requirements that govern project interconnection.

kW: kilowatt

kWh: kilowatt-hours

Material modification: A modification that changes the maximum electrical output of a project or changes the interconnection equipment including but not limited to the following:
Changing from certified to non certified equipment or replacing a component with a component of different functionality or UL listing.

MW: megawatt

Nationally recognized testing laboratory: A testing laboratory recognized by the accreditation program of the U.S. department of labor occupational safety and health administration.

Non-Flow Back: An installed electric generation project which operates in parallel with the Electric Utility with a relay protection scheme and isolation device preventing power flow back to the Utility.

Parallel Operating Agreement: An agreement between the Utility and the Customer governing the parallel operation of the generation equipment. Parallel Operating Agreement will cover matters customarily addressed in such agreements in accordance with Good Utility Practice, including, without limitation, system operation, interconnection rate, defaults and remedies, and liability

Parallel operation: The operation, for longer than 100 milliseconds, of a project while connected to the energized distribution system.

Point of Common Coupling (PCC): The point where the facilities that deliver electric power to the load (Electric Utility) meets the facility contained within a single premises or group of premises that deliver electric power to the load (Electric Utility customer).

Project: Inverter Based Projects with Aggregate Generator Output 20 kW or Less certified for anti-islanding in compliance with IEEE 1547 standards et seq Electrical generating equipment and associated facilities which are eligible for interconnection to the Electric Utility that are not owned or operated by an Electric Utility.

Project Developer: Single point of contact for the Applicant. The Project Developer may also be the Applicant and/or Customer.

Renewable energy resource: Term as defined in section 11(i) of 2008 PA 295, MCL 460.1011(i)

Renewable energy system: Term as defined in section 11(k) of 2008 PA 295, MCL 460.1011(k).

Spot network: A location on the distribution system that uses 2 or more inter-tied transformers to supply an electrical network circuit.

UL 1741: The ‘Standard for Inverters, Converters, Controllers and Interconnection System Equipment for Use With Distributed Energy Resources’, November 7, 2005 revision.

UL 1741 scope 1.1A: Paragraph 1.1A contained in chapter 1, section 1 of UL 1741, effective May 7, 2007.

Uniform interconnection application form: The standard application forms approved used for category 1, category 2, category 3, category 4, and category 5 projects.

Uniform interconnection agreement: The standard interconnection agreements used for category 1, category 2, category 3, category 4, and category 5 projects.

Uniform net metering application: The net metering application form approved used by all electric utilities and AES.

Working days: Days excluding Saturdays, Sundays, Holidays and other days when the offices of the Electric Utility are not open to the public.

Appendix D-Sample Site Plan

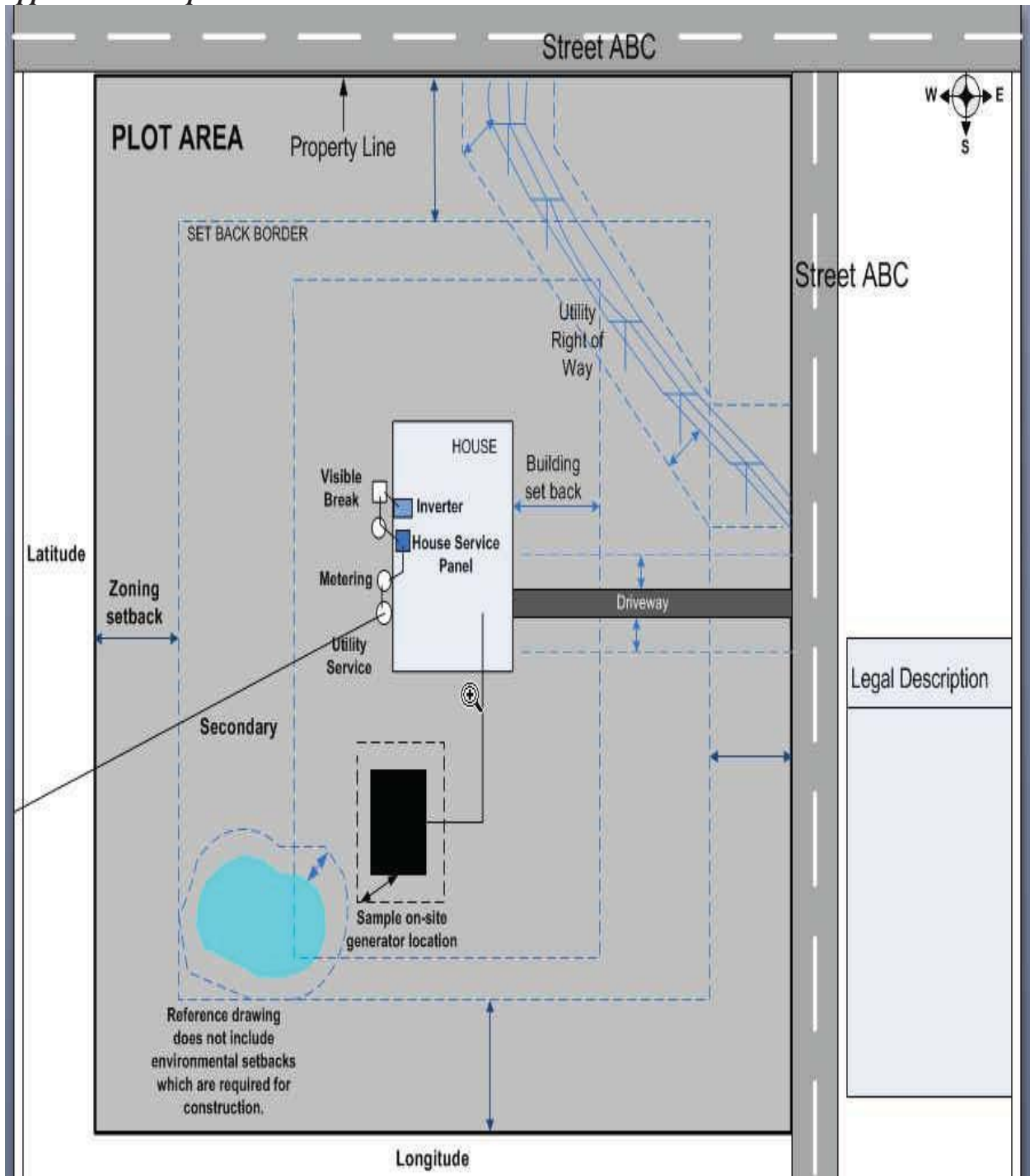

Appendix E-Sample One-Line Diagram For Flow-Back Inverter Based Projects

**Sample One-Line Diagram for Flow-Back Inverter Based Projects
With Aggregate Generator Output of 20 kW or Less certified for anti-islanding in
compliance with IEEE 1547 standards et seq.**

IEEE 1547 et seq Compliant

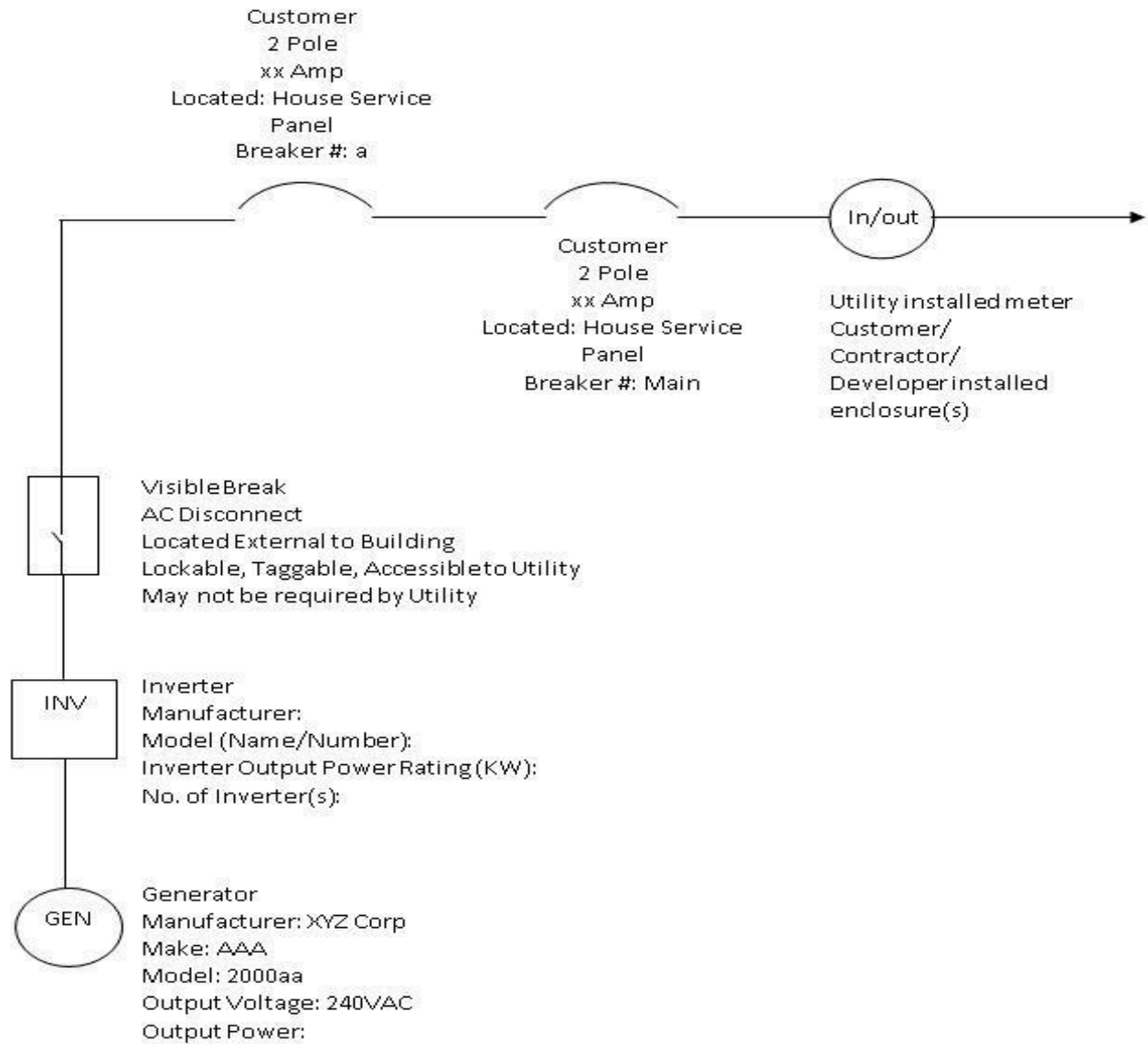

Legible Hand Drawn One-Line is Acceptable.

Appendix F-Sample One-Line Diagram for Non-Flow Back Projects

**Sample One Line Diagram for Non-Flow Back Projects
With Aggregate Generator Output of 20 kW or Less certified for anti-islanding in
compliance with IEEE 1547 standards et seq.**

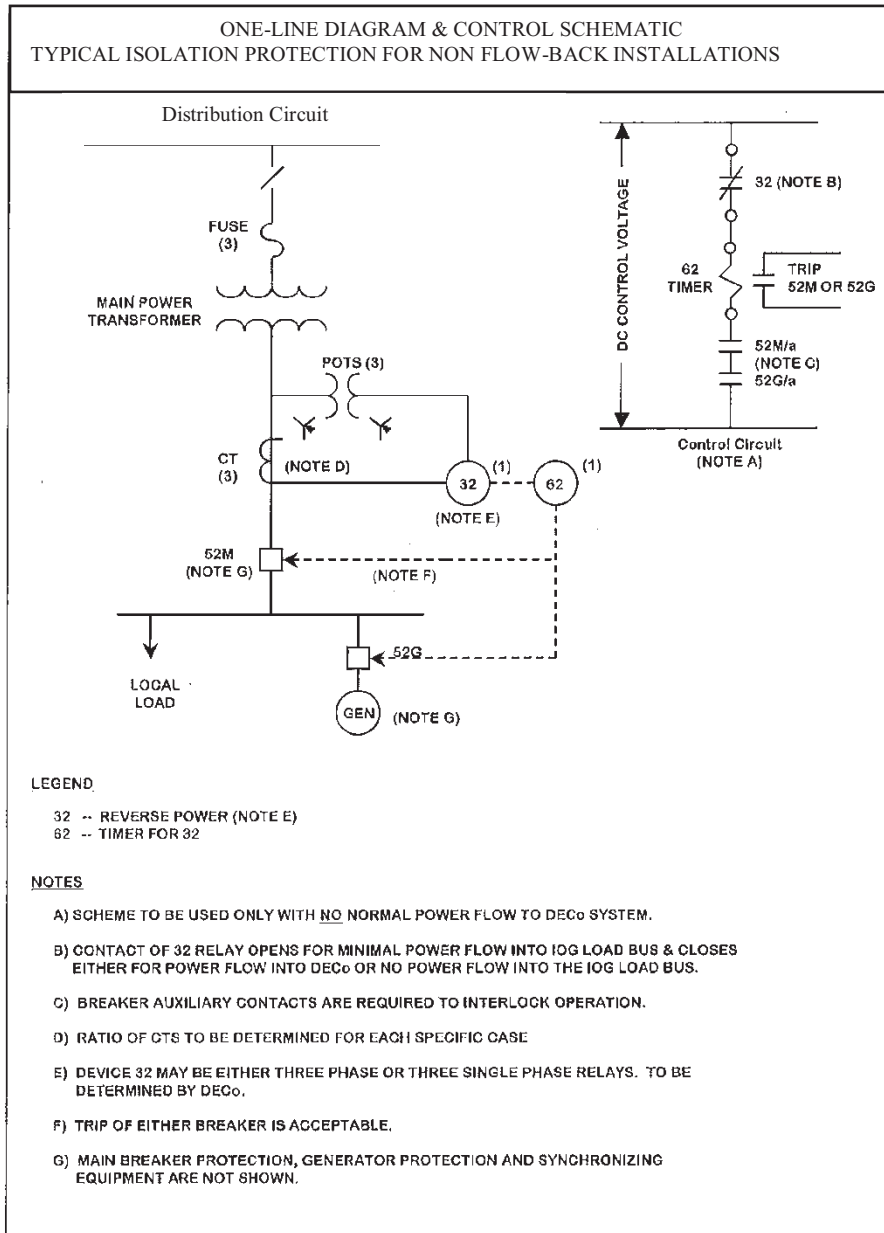

Appendix G-Sample Periodic Test Log

Sample Periodic Interconnection Test Log

IEEE 1547 5.5 Periodic Interconnection tests: All interconnection-related protective functions and associated batteries shall be periodically tested at intervals specified by the manufacturer, system integrator, or the authority who has jurisdiction over the DR interconnection. Periodic test reports or a log for inspection shall be maintained.

IEEE 1547 5.4.2 Cease to energize functionality test: Check the cease to energize functionality by operating a load interrupting device and verify the equipment ceases to energize its output terminals and does not restart/reconnect for the required time delay. The test shall be performed on each phase individually.

The electric utility recommends periodic interconnection tests but not less than the periodic interval specified by the manufacturer. If no testing interval is provided, testing shall occur every two years. The output terminals should cease to energize within 2 seconds of operation (electrically opening) of the load interrupting device during the Cease to energize functionality test. Please refer to the manufacturer for more specific information as it relates to the manufacturer recommendations for periodic interconnection tests, and reconnect time upon restoration of the load interrupting device (electronically closing).

Date	Time	Cease to Energize Functionality Test: Pass/Fail	Person Performing Test

Appendix H-Isolation Device

After review, the isolation device may not be required by the Utility. If required and/or installed, this device⁵ would be placed at the Point of Common Coupling (PCC) and must meet all of the requirements of Appendix H.

- Must be approved for use on the Utility system.
- Must comply with relevant ANSI and/or IEEE Standards.
- Must have load break capability, unless used in series with a three-phase interrupting device.
- Must be rated for the application.
- If used as part of a protective relaying scheme, it must have adequate interrupting capability. The Utility will provide maximum short circuit currents and X/R ratios available at the PCC upon request.
- Must be operable and accessible by the Utility at all times (24 hours a day, 7 days a week)
- The Utility will determine if the isolation device will be used as a protective tagging point. If the determination is so made, the device must have a visible open break, provisions for padlocking in the open position and it must be gang operated. If the device has automatic operation, the controls must be located remote from the device.

⁵ Isolation Device -A rackable circuit breaker, circuit switcher, pole top switch, load-break disconnect, etc., depending on the electrical system configuration.

Appendix I-Isolation Transformer

No isolation transformer is required between the generator and the secondary distribution connection. If an isolation transformer is used for three-phase installations, any isolation transformer connection is acceptable except grounded-wye (Utility side), delta (Project side). Protection must be provided for internal faults in the isolating transformer; fuses are acceptable. The Utility does not require the Project Developer to provide any protection for Utility system ground faults.

If a Project Developer installs an isolating transformer, the transformer must comply with the ANSI Standard C57.12 – 1999, unless a more recent standard is agreed to by the Project Developer and the Utility.

The type of generation and electrical location of the interconnection will determine the isolating transformer connections. Allowable connections are detailed in the “Specific Requirements by Generator Type” section. Note: Some Utilities do not allow an isolation transformer to be connected to a grounded Utility system with an ungrounded secondary (Utility side) winding configuration, regardless of the Project type. Therefore, the Project Developer is encouraged to consult with the Utility prior to submitting an application.

For a sample One-Line Diagram of this type of facility, see Appendix E.